



REKLUSE MOTOR SPORTS

The Rekluse Core EXP Kit for DDS Clutches

INSTALLATION & USER'S GUIDE

Doc ID: 191-7714A

Doc Rev: 081717

OVERVIEW

- This kit replaces the OEM core clutch components including the center clutch hub and pressure plate with high-quality billet components designed for optimal operation specific to your bike.
- Some of the OEM friction disks will be reused, but all OEM steel drive plates will be replaced with Rekluse TEC drive plates. Also, all 6 of the OEM drive pins will be reinstalled.

Tuning Note: (especially for 2-Stroke owners):

Upon installation of this product, if you desire your clutch to engage more aggressively, a favorable option is to purchase the heavier Belleville spring from KTM (KTM calls it the "280" spring).

KTM Part #: 78932005000

This spring will make the clutch engagement more aggressive but will slightly increase the clutch lever pull effort. This spring comes stock on 2013 and newer Factory Edition 450SX-F bikes.

INSIDE THIS DOCUMENT

- INSTALLATION
- SETTING THE INSTALLED GAP
- CHECKING FREE PLAY GAIN
- BREAK-IN
- MAINTENANCE
- EXP TUNING OPTIONS & ENGAGEMENT SETTINGS
- SLAVE CYLINDER APPENDIX (only some models)
- TROUBLESHOOTING GUIDE

INSTALLATION TIPS



- Read the safety information sheet included with your kit.
- If you install this product for a customer or another person, instruct them to read the Safety Information document and the Installation and User Guide before operating the bike with the product.
- Watch the “CORE EXP Auto-Clutch Installation Video” by following this QR code or visiting rekluse.com/videos.
- Read this entire document before performing any steps, so you will know what to expect.
- Be sure to use proper eye protection.
- Laying the bike on its left side makes clutch work easier and eliminates the need to drain the oil.
- An air or electric impact wrench works well to remove the center clutch nut, or you can place the bike in top gear and hold the rear brake while loosening the center clutch nut with a socket.
- Channel-lock pliers work best to bend the tabs of the washer up over the center clutch nut.
- Use clean, quality JASO-MA or JASO-MA2 certified transmission oil for best performance.
- Bikes with taller gearing or modified engines with increased horsepower may require heavier wedges and/or stiffer pressure plate springs which can be purchased separately from Rekluse.

TOOLS NEEDED

- 8mm socket
- 27mm socket (most models)
- 8mm & 12mm end wrenches
- 4mm & 5mm Allen keys
- Torque wrench (in-lb & ft-lb, or N-m)
- Channel-lock pliers
- Hydraulic clutch fluid
- Calipers (2 Stroke only)

INCLUDED PARTS

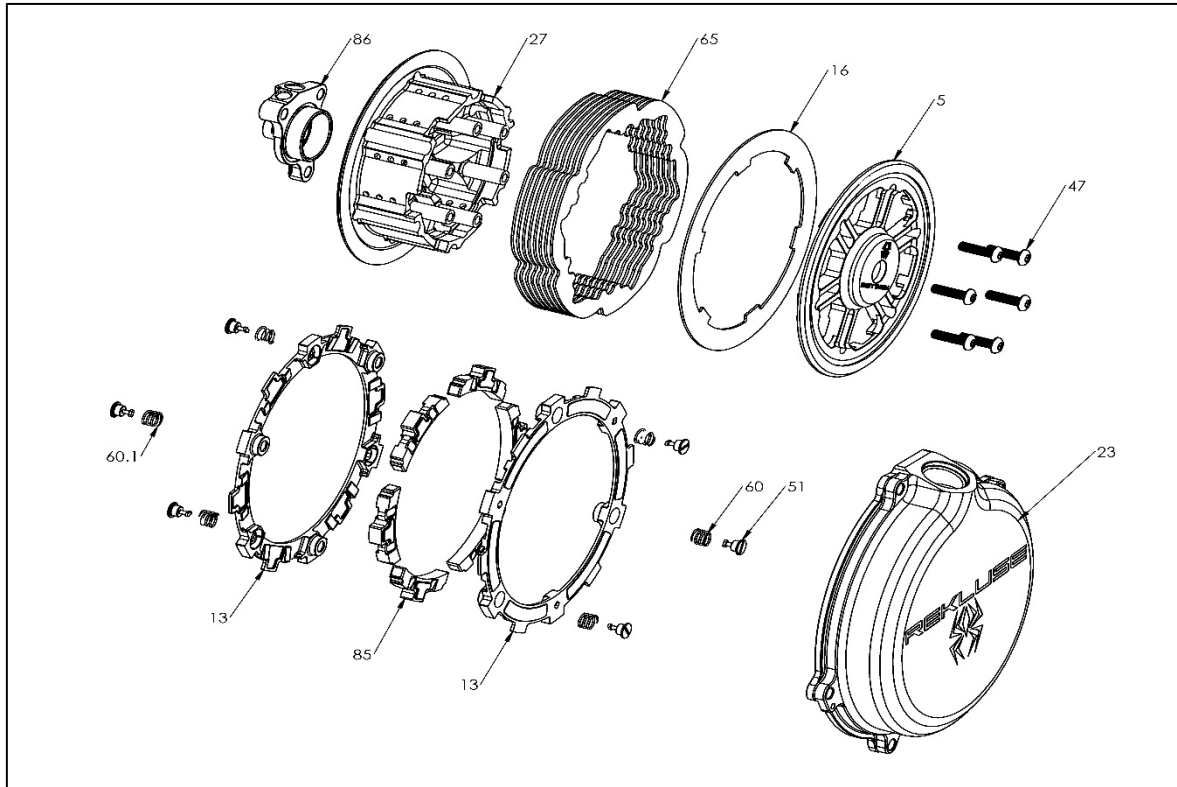

Item	Item Type	Qty
5	Pressure Plate	1
13	EXP Base *	2
16	Steel Lining Plate	1
23	Clutch Cover (Except 16+ SX-F/XC-F)	1
27	Outer Hub	1
47	Fastener - M5 x 20 T-25 Torx Screw (T-25 Torx bit included)	6
51	Fastener - 1/4-Turn Pin *	6
60.X	EXP Adjustment Spring * (extra adjustment springs are included, see last page for EXP tuning options)	6
65	TEC Steel Drive Plate (2-stroke models include extra. You will need to measure your friction disk thicknesses to determine which TEC plates to use.)	8
85	Wedge Assembly *	6
86	Adjustable Slave Cylinder Assembly (bleed syringe included)	1

* Denotes parts assembled as part of EXP disk assembly

Visit Rekluse.com/support for a full parts fiche illustration and part numbers.

For CORE MANUAL to CORE EXP upgrade kits (RMS-7580, 7582, 7584, 7585, 7586):

You will follow the instructions in this guide, with the exception of steps 5-10. Be sure to check the condition of your dampers per the “Read Me First” included document, and replace them if they have reached the recommended service interval. Also:

For all bikes: Note that your new kit includes 8 new drive plates that **must be used** instead of the ones installed in your Core Manual kit (they are different thicknesses). **THIS IS CRITICAL** to the proper operation of your clutch. Set the Core Manual drive plates aside and use the new ones.

For 2-strokes: Note that your new kit includes extra drive plates. See the “Install Clutch Pack” section for instructions. Correct installation **IS CRITICAL** to the proper operation of your clutch.

BIKE PREP & DISASSEMBLY

1. Lay the bike on its left side. Catch any fuel that might drain in a suitable container. Remove the clutch cover.



NOTE: Take note of each OEM clutch cover bolts specific location as length can vary between them. Failure to replace these bolts in the proper location after clutch installation can result in damage to your motorcycle.

2. Remove the OEM parts named in the following diagram. Note the orientation of the Belleville spring and quantity of clutch plates removed.

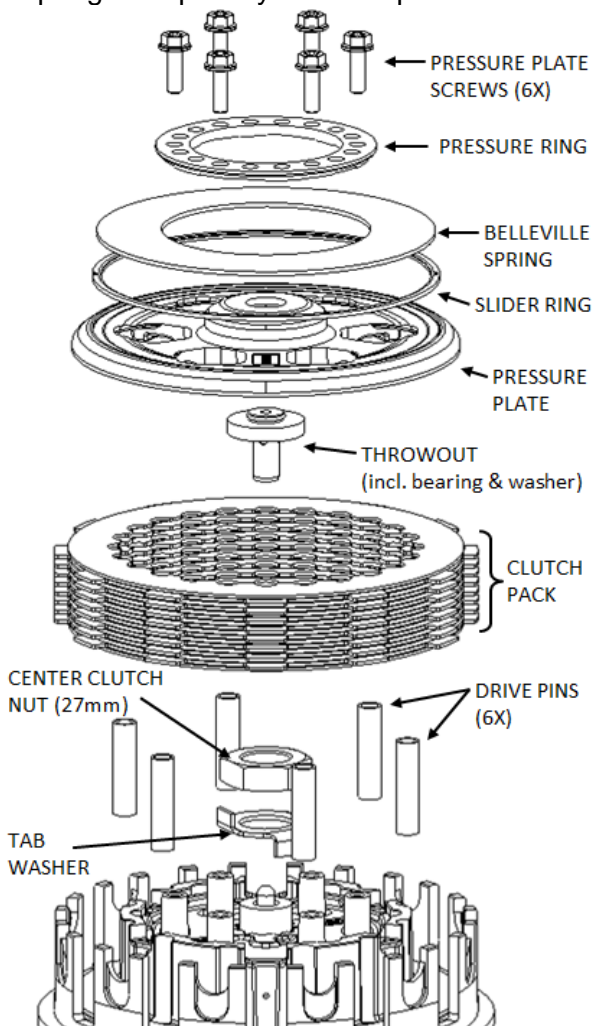

Tips:

- a. Use a hammer and large screwdriver to bend down the tabs of the tab washer.

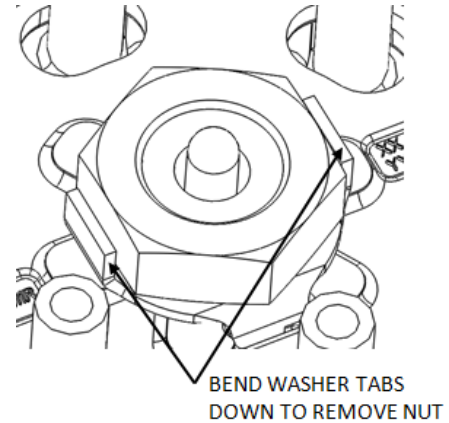

- b. Be careful that the drive pins do not fall into the engine while disassembling.

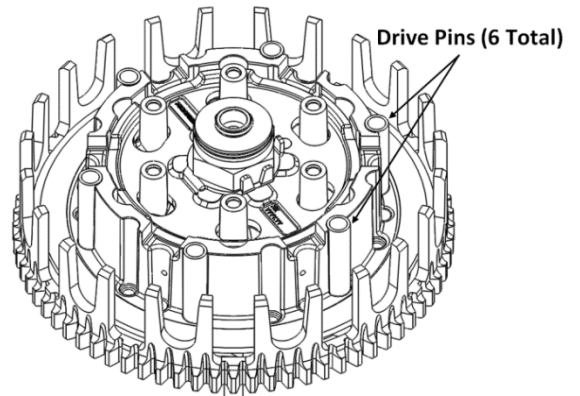

3. Separate the clutch pack.

NOTE: 8x friction disks are in the OEM clutch pack, but only 7x will be reused with the *CoreEXP* clutch pack.

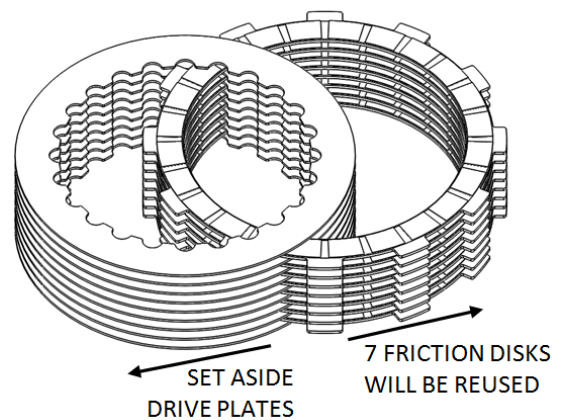

4. Inspect the friction disks for signs of heat or wear. Replace if they are burnt or worn with **KTM Part #: 5903201100.**

5. Soak the EXP disk in engine oil for 5 minutes.

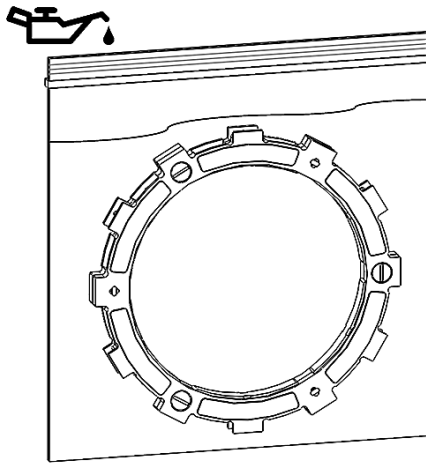

6. Remove the center hub assembly from the bike. Make sure the thrust washer is in place on the main shaft and not stuck to the bottom of the center hub assembly.

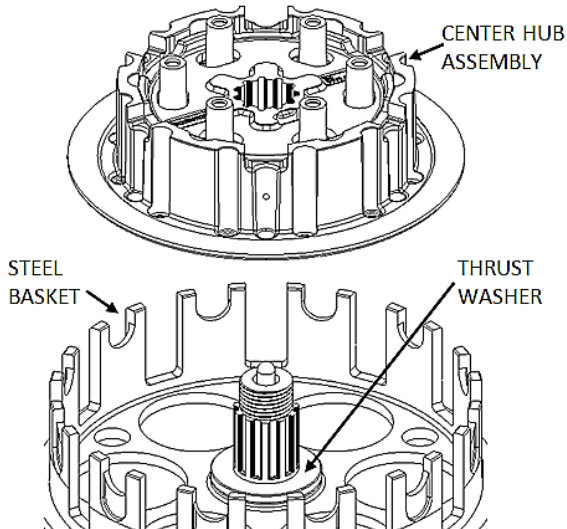

7. With the center hub assembly in your hands, place your thumbs on the inner hub at the location of the embossed part numbers and try to spin the inner hub back and forth inside the outer hub. Rekluse recommends replacing the dampers if you feel any slop between the two hubs.



8. Remove the 6 rubber dampers from the OEM center hub assembly.

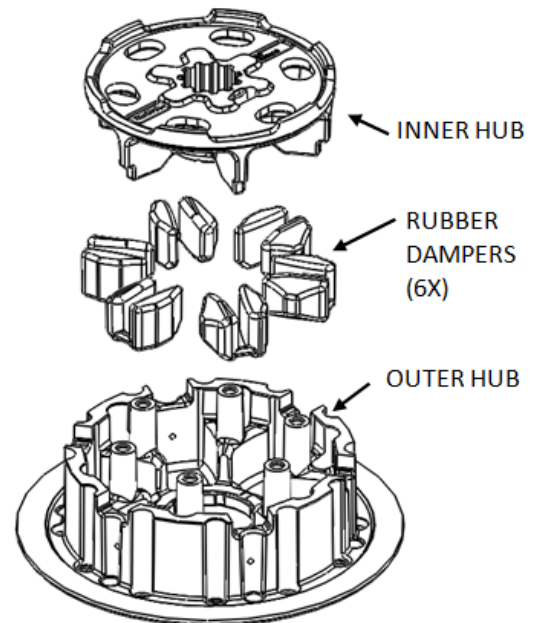

NOTE: The OEM dampers inside the center hub assembly shrink due to heat and use. Loose or sloppy dampers will shorten the life of your clutch. Inspect the dampers before proceeding and replace if necessary. Inspect the dampers using the procedure described in the “Read Me First” document, or by the following procedure.

Inspecting the dampers by hand:

INSTALL HUBS

1. Install the 6 OEM rubber dampers and OEM inner hub onto the Rekluse Outer Hub.

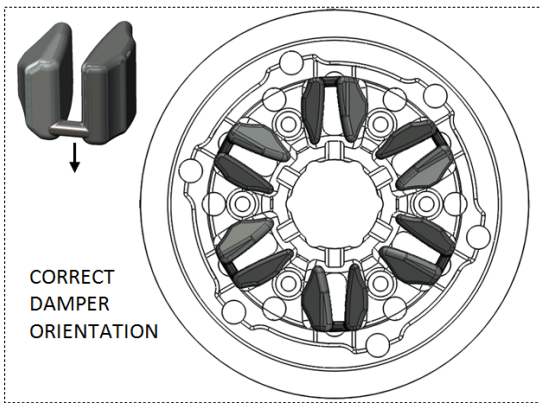
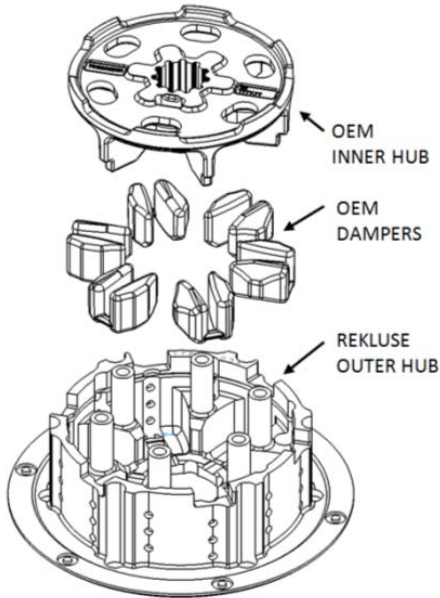

2. Install the new Center Hub Assembly into the clutch basket.

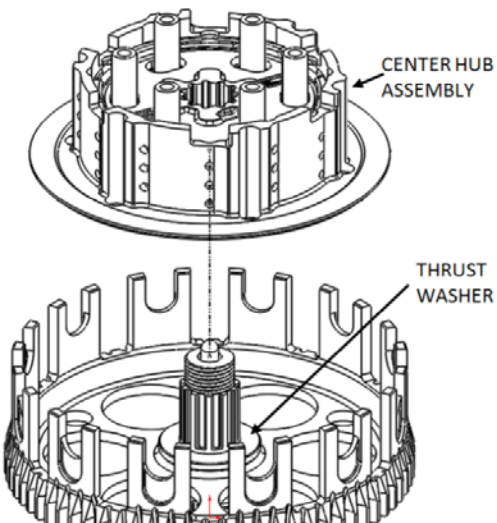

3. Reinstall the OEM tab washer and center clutch nut. Torque the nut to **50 ft-lb (68 N-m)**.
4. Bend up **both** tabs of the tab washer using channel-lock pliers. The tabs can be bent on the straight sides or around the corners.

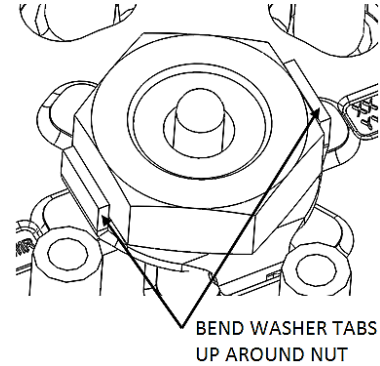

5. Seat the 6 OEM drive pins into the Rekluse outer hub.

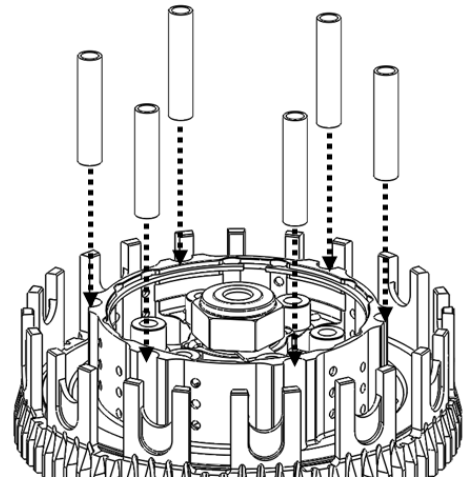

INSTALL CLUTCH PACK

2017+ 250F, 2017+ 350F and 2-STROKES only:

If your bike is not a 2017+ 250F, 2017+ 350F or a 2-Stroke, skip to step 6.

Certain friction disks in some models are thicker than others, and these differences can greatly affect the overall performance of your clutch and stiffness of your clutch lever pull. The output force of the Belleville spring in your clutch is very sensitive to the clutch pack thickness. Your kit includes 3x extra (thinner) .040" TEC drive plates to compensate for the variation in friction disk thickness if necessary.

Included are **8x** .048" [1.2mm] and **3x** .040" [1.0mm] drive plates. **Only 8x total** drive plates will be used in the clutch pack, but you must measure the friction disk thickness to determine if any of the thinner plates must be used instead in the final clutch pack to compensate.

Wipe the excess oil from **7x** of your OEM friction disks and stack them together with **8x** .048" [1.2mm] drive plates, as well as the EXP disk. Using calipers, measure the overall thickness as shown:

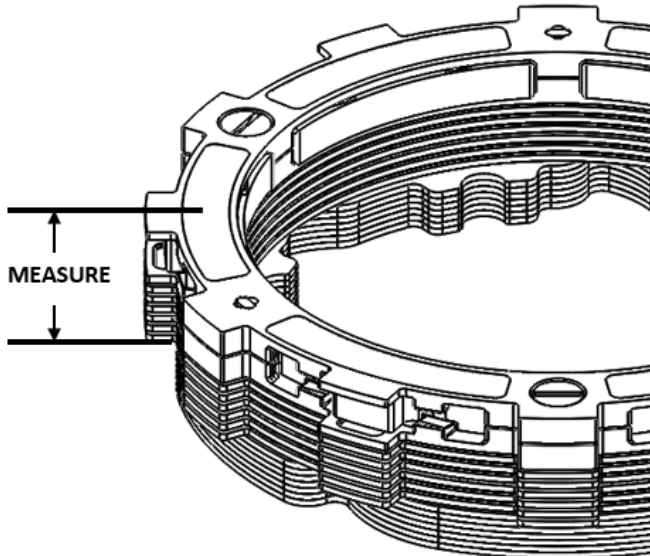

This measurement needs to be 1.343"-1.355" [34.1mm-34.4mm] tall. If it is taller than that, take out **1x** .048" [1.2mm] drive plate and replace with **1x** .040" [1mm] drive plate and remeasure. Repeat until the desired pack thickness is attained.

6. Install the first TEC drive plate in the orientation shown (all drive plates will follow this orientation).

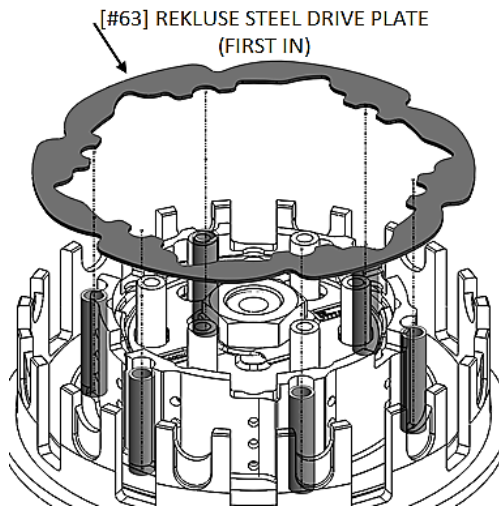

NOTE: Proper orientation of the drive plates is **critical** for optimal clutch performance. If you install them backwards, the clutch will still function but will lack proper modulation performance.

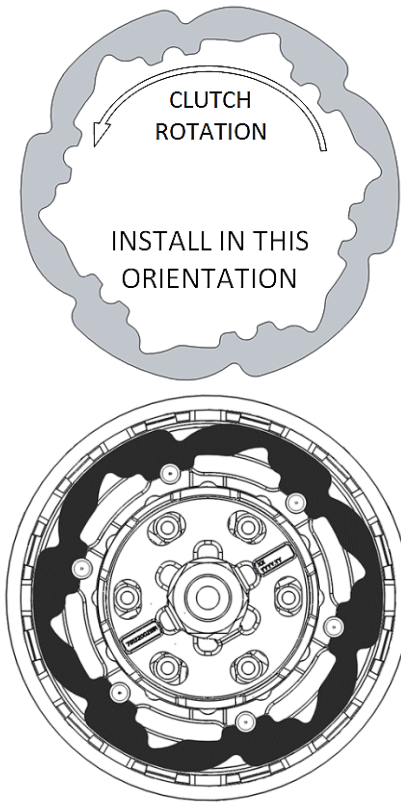

7. Install the rest of the clutch pack, using **8x** Rekluse steel drive plates and **7x** OEM friction disks in total.

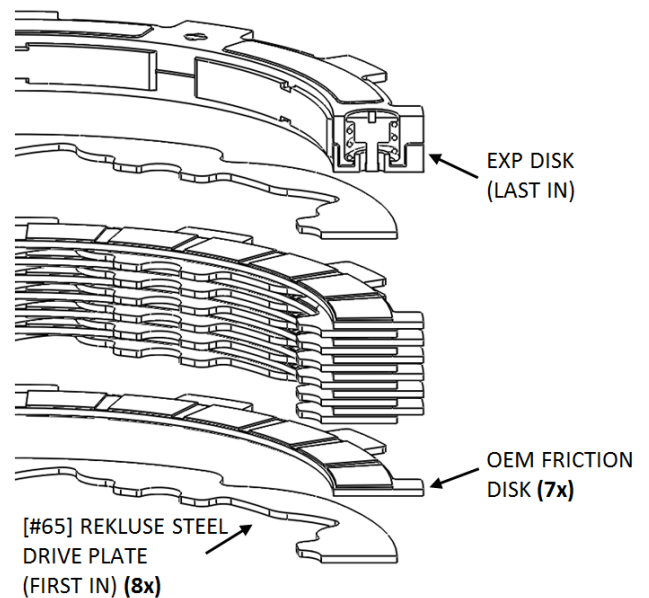

8. Install the EXP disk on top of the last steel plate. Make sure that the EXP disk is seated in the same slots as the clutch pack.

NOTE: Some OE basket have “half slots” at the top of the basket tangs. Rekluse products require the entire clutch pack, including the EXP disk, be installed into the MAIN (deeper) basket slots.

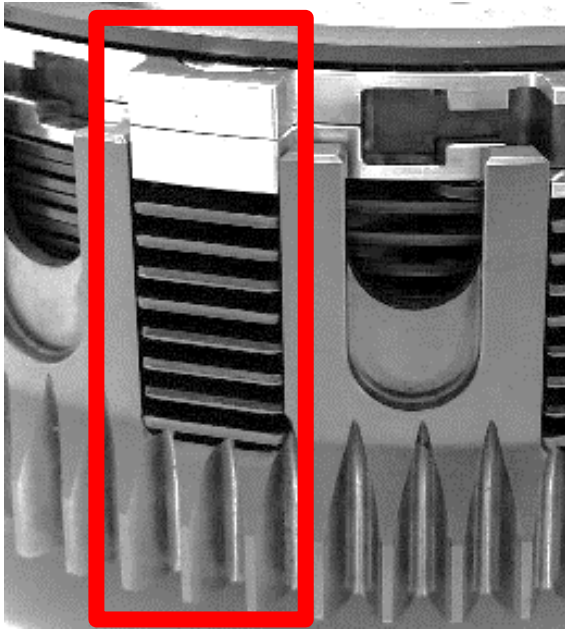

9. Reinstall the OEM throw-out.

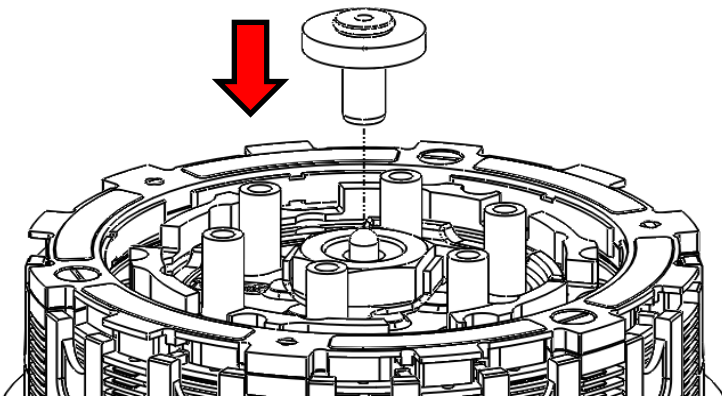

PRESSURE PLATE INSTALLATION

10. Place the steel lining plate onto the Rekluse pressure plate. Adding an oil film between them will help them stick together for ease of installation.

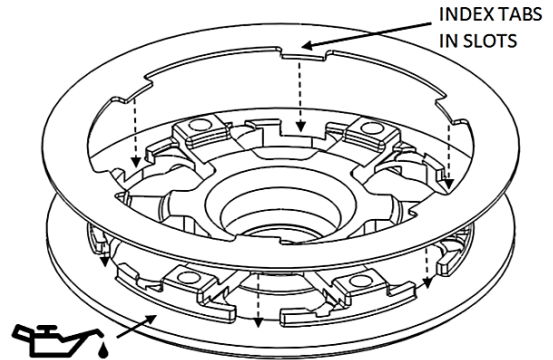

11. Install the pressure plate subassembly.

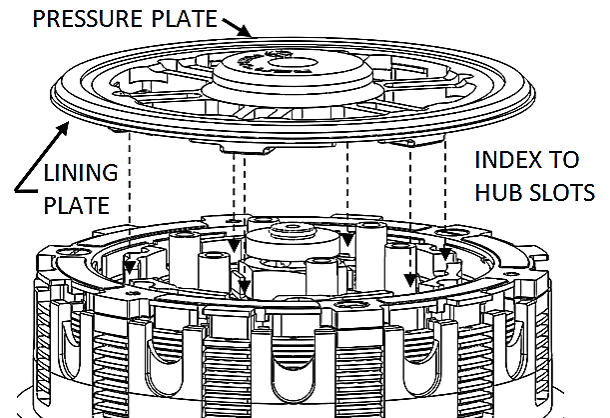

12. Install the OEM slider ring on the pressure plate with the “top” marking facing up. (The top side is rounded and the bottom edge is sharp.)

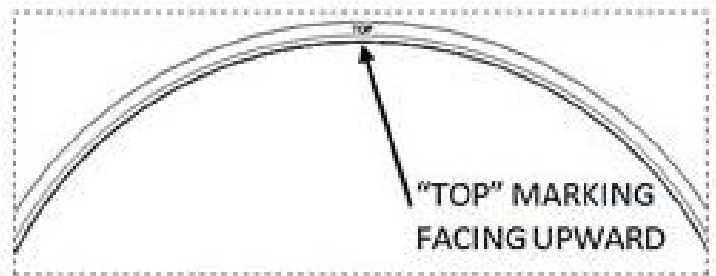

13. Place the OE Belleville spring onto the slider ring, with the rounded dome side facing up.

NOTE: The outer edge of the Bellville spring will make contact with the Slider Ring. If it does not, the Bellville spring is upside down.



Correct – The Belleville spring sits flat against the slider ring.



Incorrect – The Belleville spring is upside down.

14. Install the OEM pressure ring followed by the Rekluse pressure plate screws.

CAUTION:
DO NOT reuse the stock screws, or clutch cover interference will occur!

DO NOT over-torque the screws, or damage to the screw heads will occur!

NOTE: There are 3 possible settings on the OEM Pressure Ring. Rekluse recommends setting II (4-strokes) or II (2-strokes) for optimum clamping force and performance.

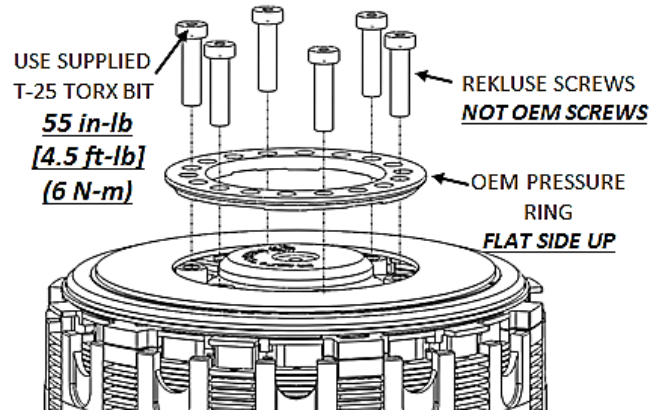

15. Install the OEM gasket onto the Rekluse clutch cover.

16. Install the Rekluse clutch cover by lightly tightening the cover bolts in a star pattern. Tighten bolts in small increments before torqueing all the cover bolts to OEM specification – 7.4 ft-lb (10 N-m).

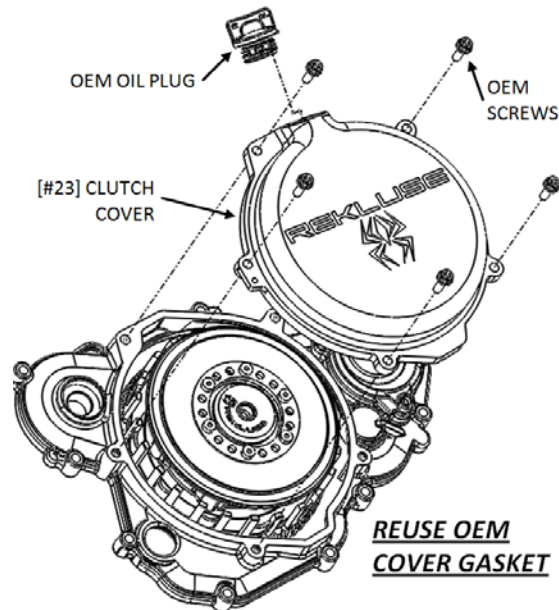

CAUTION:
Failure to install the OEM clutch cover bolts back in their proper location can result in damage to your motorcycle. Be sure to torque the bolts in a star pattern. The clutch cover may crack or break if too much torque is applied at once or if bolts are tightened in a different pattern.

SLAVE CYLINDER INSTALLATION

Please read the entire section before beginning the process of installing the Rekluse slave cylinder.

Handle with care! During assembly there is a small ball bearing installed in the slave piston with a small amount of grease. When installing the Rekluse slave cylinder, make sure the ball is in place and has not come loose.

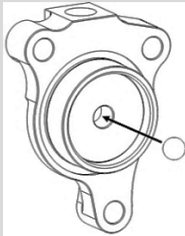

17. Stand the bike up and lean it on its kickstand or place it on a suitable bike stand.

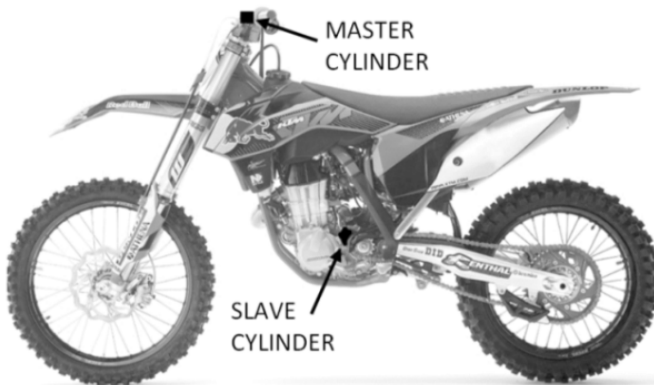

18. On a workbench (away from the engine), bleed the Rekluse slave cylinder using the following procedure:

a. Use a 4mm Allen key to make the top O-Ring visible on the adjuster screw.

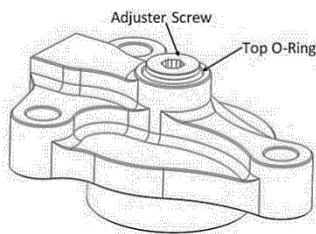

b. Compress the piston until it bottoms.

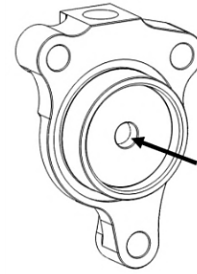

c. Pour clutch fluid into the slave cylinder port.

CAUTION:

Be sure to use the correct clutch fluid! Check the cap of the clutch master cylinder to determine which clutch fluid to use. Failure to use the correct fluid will result in seal damage and/or failure.

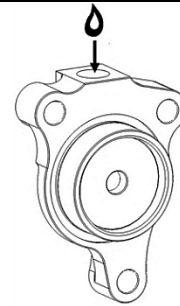

d. Turn the adjuster screw clockwise until it bottoms, keeping the fluid topped off as you go.

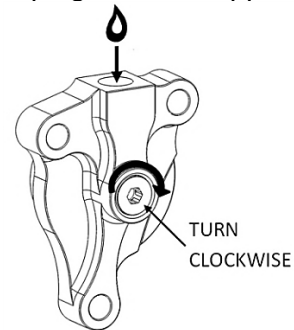

e. Turn the adjuster screw back to the initial position with the top O-ring visible.

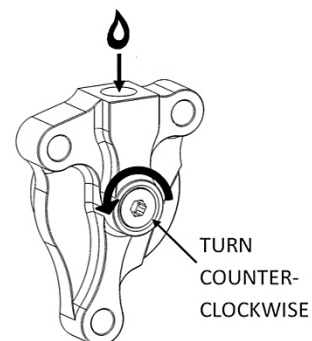

- f. Compress the piston until it bottoms out. Repeat steps **c** – **f** until there is no longer air escaping from the top port when the piston is compressed.

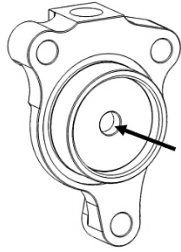

NOTE: When compressing the piston, fluid can shoot out from the slave cylinder port. Be sure to wear eye protection.

- g. When bleeding is complete, turn the adjuster screw counterclockwise so that the top O-ring is visible.
 h. Compress the piston until it bottoms out, and top off with fluid.

19. Check that the ball bearing is still in place, then set the Rekluse Slave Cylinder aside, standing in an upright position so that it does not spill any fluid.

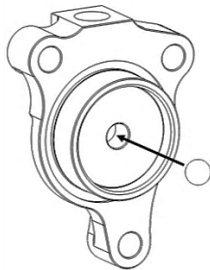

20. Stand the bike up and lean it on its kickstand or place it on a suitable bike stand.

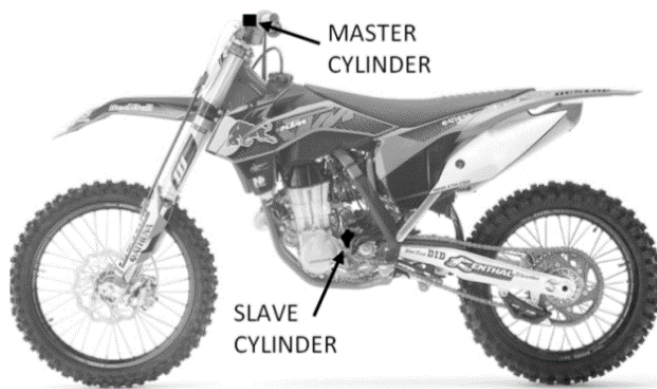

NOTE: Some 2017 FE450/501 slave cylinders have the banjo bleeder bolt and some have the straight fluid line. Follow the instructions based on the type of fluid line on your bike.

21. On the left side of the bike, while leaving the OEM slave cylinder bolted on the engine, use a wrench to remove the banjo bleeder bolt from the OEM slave cylinder.
 22. Remove the clutch fluid line and the 2 OEM crush washers from the OEM slave cylinder.

- **2017+ FE450/501:**
Remove the OEM fluid line fitting

23. Set the banjo bleeder bolt and the OEM crush washer aside. They will not be reused.

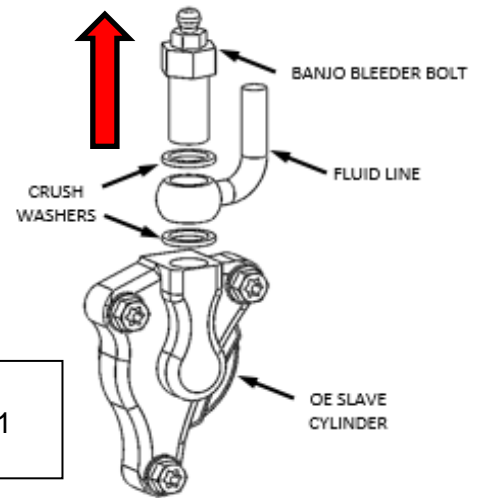

KTM 450/500
FC/FX 450/501

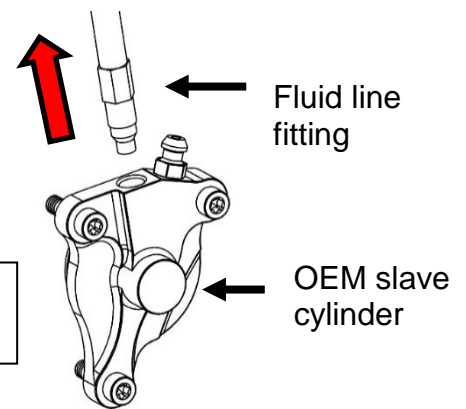

2017+ FE
450/501

NOTE: A quick transfer of the fluid line will result in less bleeding in the following steps.

24. Attach the clutch fluid line to the Rekluse slave cylinder using the supplied banjo bolt and the 2 new crush washers from Rekluse. Make sure the clutch fluid line is between the 2 crush washers.

- **2017+ FE450/501:**
Attach the clutch fluid line directly to the Rekluse slave cylinder. You will not use the crush washers.

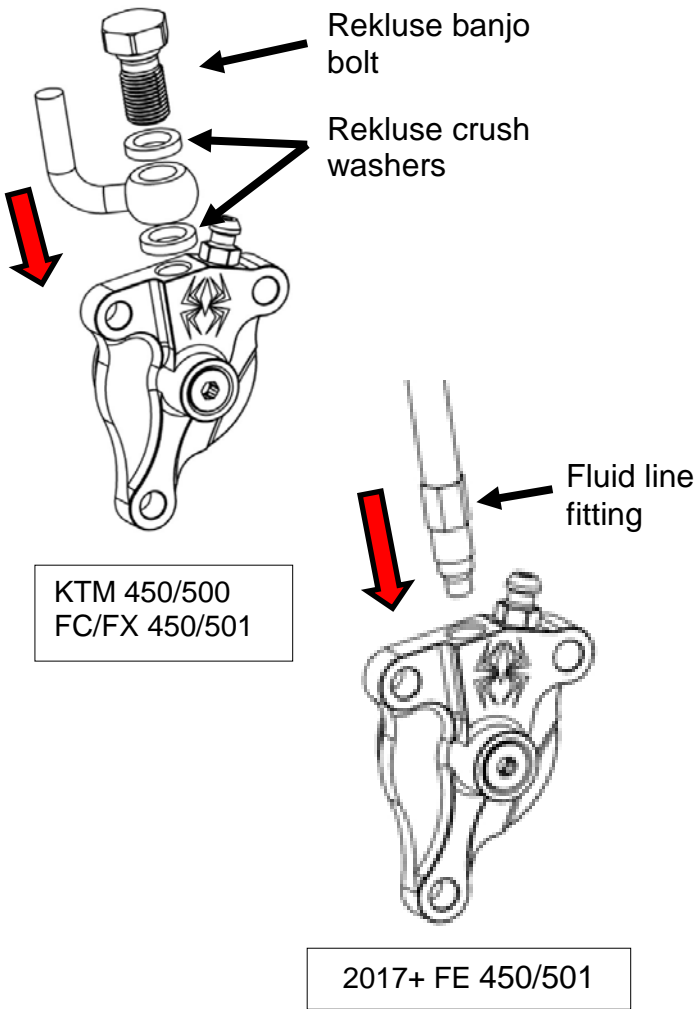

25. Tighten the banjo bolt (or fluid line fitting) with your hand until snug. (You will torque it to spec once installed on the bike.)

26. Remove the cap and bladder from the clutch master cylinder.

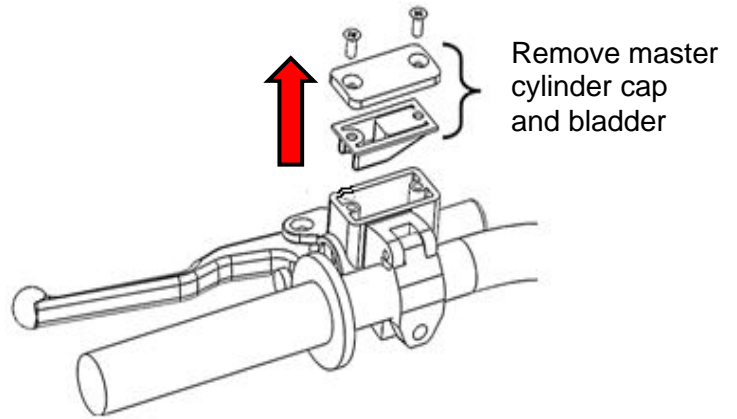

27. With the clutch fluid line attached to the Rekluse slave cylinder, remove the OEM slave cylinder from the engine. Keep the OEM bolts for reuse.

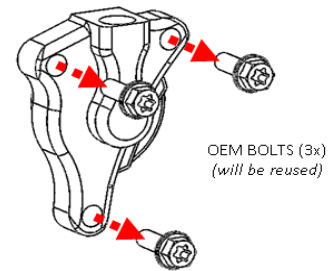

28. Mount the Rekluse slave cylinder to the engine using the OEM bolts.

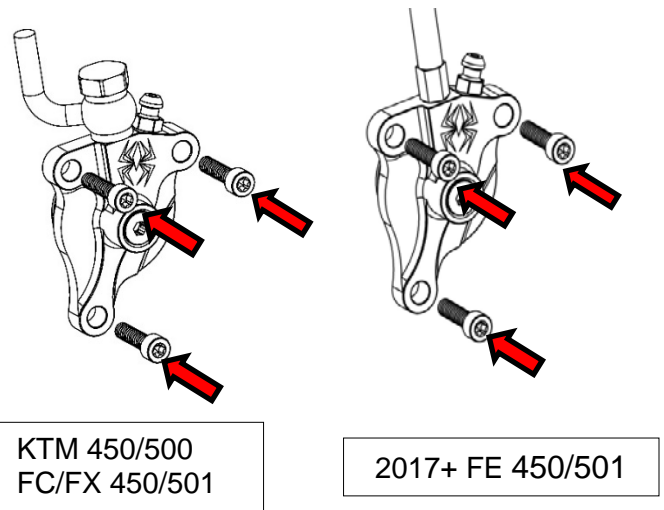

NOTE: Some models have a piston diaphragm seal. **DO NOT REUSE** them if OEM equipped.

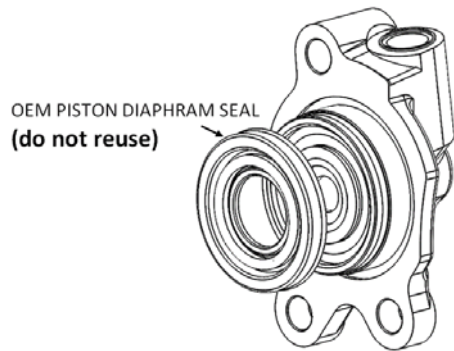

NOTE: When installing case sealing O-ring seal (OEM or Rekluse supplied) ensure it is seated against slave cylinder flange.

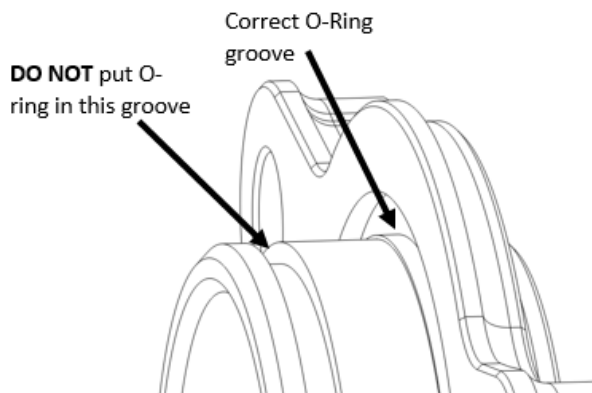

NOTE: The Rekluse slave cylinder comes preassembled in the kit. If the parts become separated, assemble them in the following order: Rekluse slave cylinder, O-ring, then the supplied paper gasket.

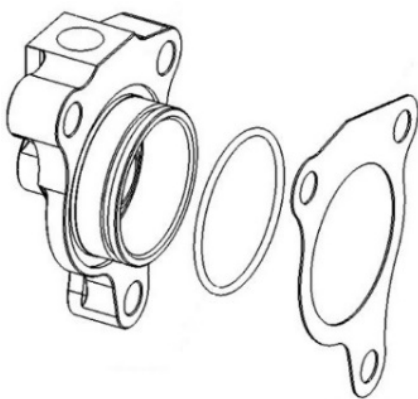

29. Torque the banjo bolt to 18 ft-lb (25 N-m) per OEM specification.

30. Optional: If you purchased the Rekluse Slave Guard accessory, install it now using the instructions in the kit.



31. Attach the supplied bleed tube to the banjo bolt port and loop it into a suitable catch bottle.

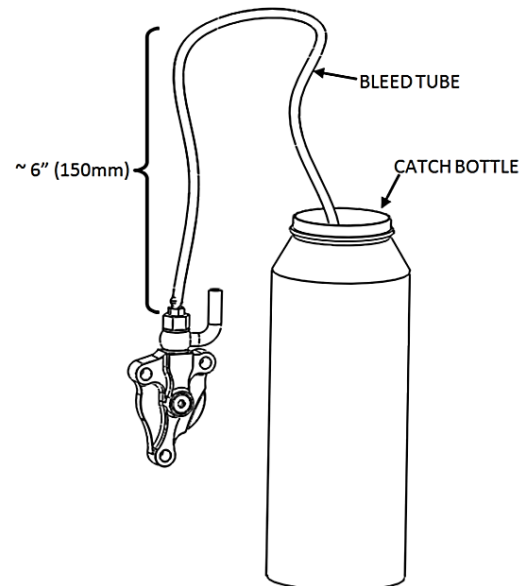

32. Pump the clutch lever 3-5 times then hold it against the bar/grip.

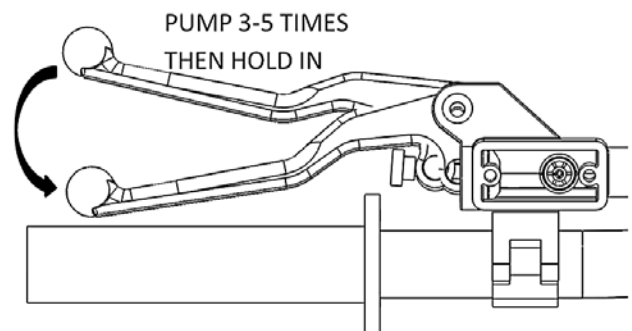

33. Using an 8mm wrench, open the bleed port. Air and fluid should come out of the bleed tube. Tighten the bleed port.

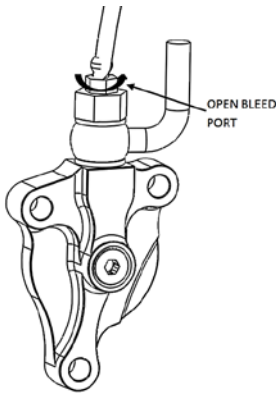

34. Slowly release the clutch lever and check the fluid level in the clutch master cylinder. Top off if necessary.

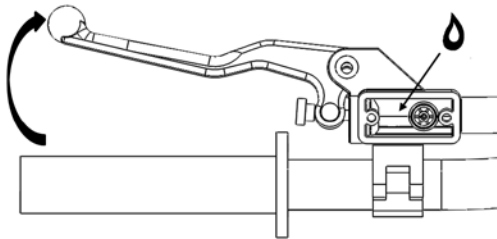

35. Repeat the previous 3 bleeding steps until air no longer comes out of the bleed port. Then, check that the clutch lever functions properly. Repeat the bleeding procedure if necessary.

36. Check that the clutch master cylinder is 75% full, then replace the cap and bladder on the clutch master cylinder.

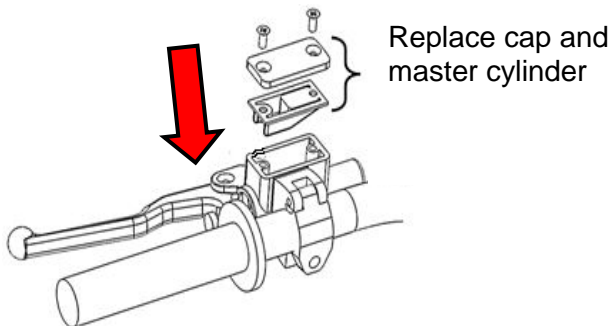

37. Remove the bleed tube and bottle, then torque the bleed screw to 150 in-lb (17 Nm).
38. Finally, replace the rubber dust cap over the bleeder screw.

INSTALLED GAP SETTING

DEFINITION: “Installed Gap” is the separation in the clutch pack created by the adjustment of the Adjuster Screw in the Slave Cylinder. This gap is what allows the clutch to spin freely until the desired RPM is reached for engagement; it must be set correctly for optimal performance.

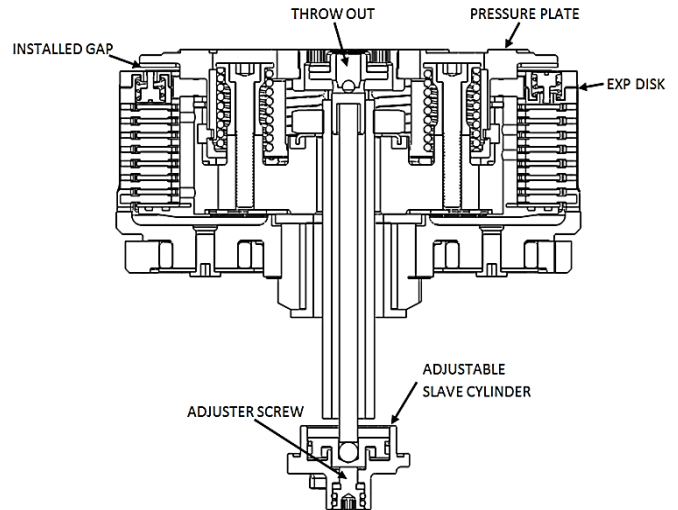

- Using the long end of a 4mm Allen key, turn the adjuster screw clockwise until it stops under moderate pressure. You are trying to feel for the point at which the throw-out will start to lift the pressure plate. This is the “starting point.”

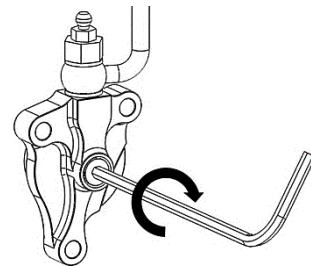

NOTE: It may take a few tries to find the point at which the system is bottomed-out. You should feel a distinguishable change in turning effort at this point.

- Once you have found the starting point, turn the adjuster clockwise 1 full turn. **This is NOT your final setting**, but it is a good reference point for using Free Play Gain to find the correct setting. Expect the bike to drag in gear until proper Free Play Gain is achieved.

CHECKING FREE PLAY GAIN

WARNING

Always make sure that the bike is in NEUTRAL before checking Free Play Gain. Failure to do so may result in the bike lurching forward, and loss of control and/or injury may result.

NOTE: Before performing this step, please visit our website at rekluse.com/support to view the TECH VIDEO entitled “How to Check Free Play Gain”.



“**Lever Free Play**” is essentially the “slack” in the clutch lever before it starts actuating the clutch. Applying a light finger pressure will take up this slack.

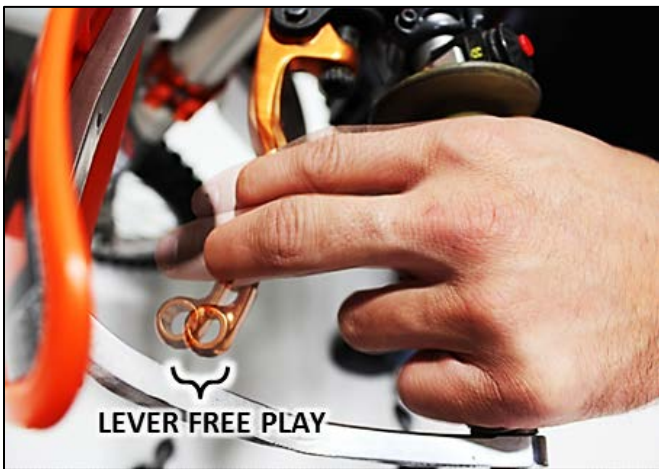

“**Free Play Gain**” is the increase of lever free play as the auto-clutch engages. This happens when the RPM increase from idle through around 5000 RPM. Free Play Gain is caused by the expansion of the EXP disk which lifts the pressure plate away from the throw-out assembly.

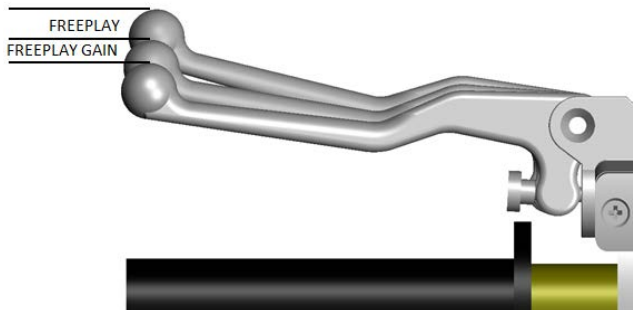

Optimal Free Play Gain yields **1/8” (3mm)** of clutch lever movement, measured at the end of the lever. This measurement at the lever correlates to achieving the ideal installed gap.

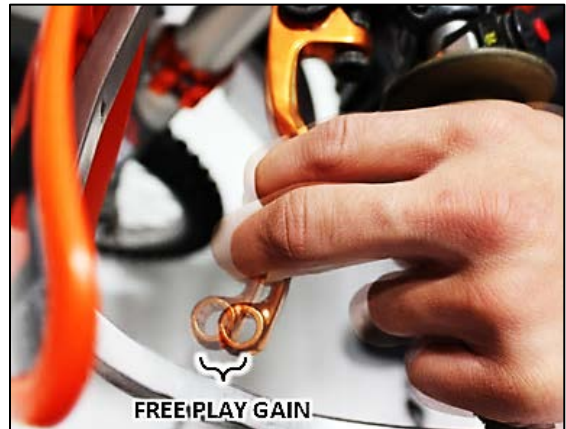

The following steps explain two ways to check Free Play Gain. One will use the rubber band that has been included in the clutch kit and one explains using your hand, which you will perform before every ride.

Place the bike in neutral, start the engine and let it warm up for 2-3 minutes.

Rubber Band Method:

It is recommended that you use this method first to find your Free Play Gain so you can see what it is. Then, check it by hand as well so that you can effectively and comfortably check Free Play Gain every time you ride.

Wrap the included rubber band around the outer end of the handlebar grip and attach it to the ball end of the clutch lever.





With the bike at idle in neutral, **quickly** blip (rev) the engine to at least 5,000 RPM and let it return to idle. **The clutch lever should move in about 1/8" (3mm) toward the handlebar as you rev the engine.** Turn the Slave Cylinder adjuster screw clockwise 1 tick at a time until optimal clutch lever movement (i.e. **Free Play Gain**) is achieved.

Note: If you are not getting the correct lever movement, see the "Free Play Gain Troubleshooting Guide" on the next page.

Hand Method:

Free Play Gain should also be checked using your hand, as you will check it by hand before every ride. With the bike at idle, apply enough pressure to the lever to take up the initial freeplay (slack) shown in the photos on the previous page. While continuing to apply light pressure, rev the engine to at least 5,000 RPM. **The clutch lever should move in 1/8" (3mm) under your finger pressure as you rev the engine and the auto-clutch engages.**

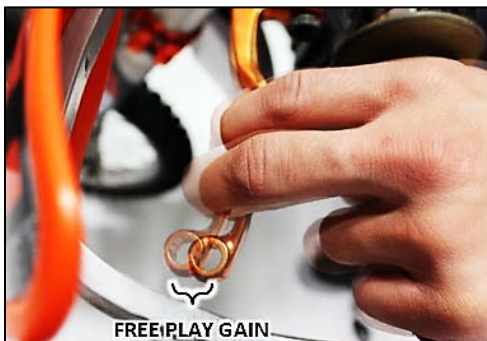

BREAK – IN

Follow these procedures for a new installation and any time new friction disks or EXP bases or wedges are installed.

1. Rev cycles: Warm up the bike for 2-3 minutes. With the bike in neutral and your hand **off** of the clutch lever, rev the engine 10 times, being sure to let it **return to idle** between each rev cycle.
2. With the engine running, pull in the clutch lever and click the bike into gear. Slowly release the clutch lever. The bike should stay in place, perhaps with a slight amount of forward creep.
3. Now that the bike is idling in first gear, slowly apply throttle to begin moving. To break in the clutch components, perform the following roll-on starts in 1st and 2nd gear without using the clutch lever: In 1st gear, accelerate moderately to approximately 5,000 RPMs and come to a stop—repeat this 5 times. Next, starting in 2nd gear, accelerate moderately to approximately 5,000 RPMs then come to a stop—repeat this 5 times.
4. Now that the EXP is broken-in and the clutch is warm, recheck Free Play Gain at your clutch lever and adjust if necessary. Your clutch pack will expand with heat, so final adjustments should be made when the bike is warm. Now you are ready to ride! You may need to readjust your Free Play Gain during the first ride or two, so continue to check FPG frequently.

WARNING: DO NOT RIDE WITHOUT SUFFICIENT FREE PLAY GAIN!

Checking Free Play Gain is easy and takes less than a minute to perform. For optimum performance and longevity, check Free Play Gain when the bike is warm at the start of every ride.

FREE PLAY GAIN

TROUBLESHOOTING

Each adjustment should be done in small increments - one tick mark at a time. After each adjustment, repeat the rev-cycle until optimal Free Play Gain is achieved.

Symptom:

- Clutch lever moves in too far (too much Free Play Gain)
- Clutch has excessive drag
- It is difficult to fully override the clutch with the lever
- Shifting is difficult

Answer: Installed Gap is too small

Solution: Turn the Adjuster Screw inwardly (clockwise) to increase the Installed Gap.

Symptom:

- Clutch lever does not move enough or does not move at all (too little Free Play Gain)
- Clutch is slipping

Answer: Installed Gap is too large

Solution: Turn the Adjuster Screw outwardly (counterclockwise) to reduce the Installed Gap. It may be helpful to re-find the starting point.

CLUTCH NOISE

Although it is harmless, some bike models may have “squeal” or “chatter” coming from the clutch at low RPM as it engages. Clutch squeal is caused by the clutch components vibrating as the clutch engages and can become more audible as the clutch gets hot. For bike models that tend to have clutch squeal or chatter here are some recommendations to reduce or eliminate it:

- **Oil:** Rekluse recommends that you have fresh, clean JASO-MA rated oil for best clutch performance. Dirty or old oil can make the clutch more likely to squeal or chatter. Some heavy-duty oil stabilizers or other additives have been known to reduce noise and make shifting smoother. Be sure that any additives you might use are approved for use in wet-clutch motorcycles.
- **Clutch Basket:** Available for some models, a Rekluse Clutch Basket will eliminate clutch squeal and chatter in most cases because it is precision machined from high quality material and includes long-life clutch dampers. A clutch basket that is damaged or has worn-out dampers tends to increase clutch noise.
- **Installed Gap:** Adjusting the Installed Gap will NOT affect clutch squeal or chatter

MAINTENANCE

- Maintain adequate Free Play Gain, checking before every ride and adjusting if necessary.
- Keep up with regular oil changes as per the bike manufacturer's recommendations. Clutch function and longevity depends on oil quality.

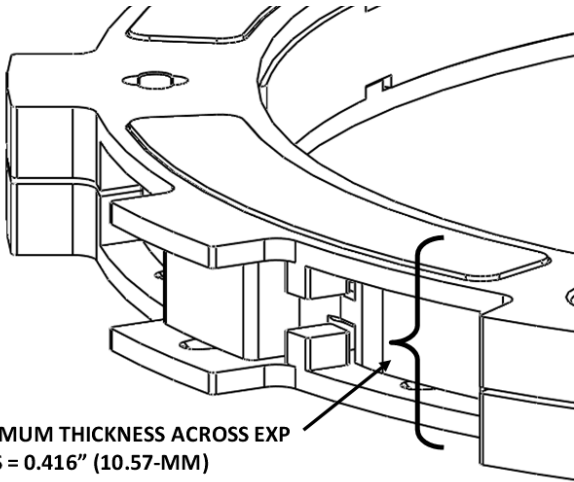

- Repeat the break-in procedure anytime the friction disks or EXP bases or wedges are

replaced. Always soak friction disks or EXP bases in oil for at least 5 minutes before installing.

- To prolong the life of the clutch, inspect your rubber hub dampers **every 20 hours** for 450 SX-F models (including factory edition), and **every 30 hours** for all other bikes. Replace the dampers if the interaction between the two hubs is loose or sloppy. See the "Read Me First" page for inspection procedure.
- Inspect all of your clutch parts for signs of wear or excessive heat, and replace components as necessary according to the OE service manual.

EXP TUNING OPTIONS

Included are spring options to tune the engagement RPM of the EXP disk. The EXP disk comes set with the recommended “Medium” setting from Rekluse.

ENGAGEMENT SETTING	SPRING CONFIGURATION			
	350 4-stroke	450/500/501 4-stroke	250/300 2-stroke (Pre 2017)	250/300 2-stroke (2017+)
Low	6 Silver	6 Blue	6 Silver	6 Steel
Medium	3 Silver & 3 Red	3 Blue & 3 Gold	3 Silver & 3 Red	3 Silver & 3 Steel
High	6 Red	6 Gold	6 Red	6 Silver

Adjusting the engine idle speed to match your engagement setting is important and greatly affects the overall feel of how the EXP disk engages. To prevent freewheeling and maximize engine braking, set the idle so there is a slight amount of drag while the bike is idling in gear and warmed up. The idle should not be so high as to move the bike forward in gear with the throttle closed. However, with a small opening of the throttle the bike should move forward.

It is **NOT necessary** to disassemble the EXP halves to change springs! To change springs, remove 3 of the ¼-turn pins from one side of the EXP, replace springs, and reinstall ¼-turn pins. Next, flip the EXP disk over and repeat on the other side if necessary. To maintain even pressure when using two different color spring sets, install one color set of 3 on one side of the EXP and the remaining color set of 3 on the other side.

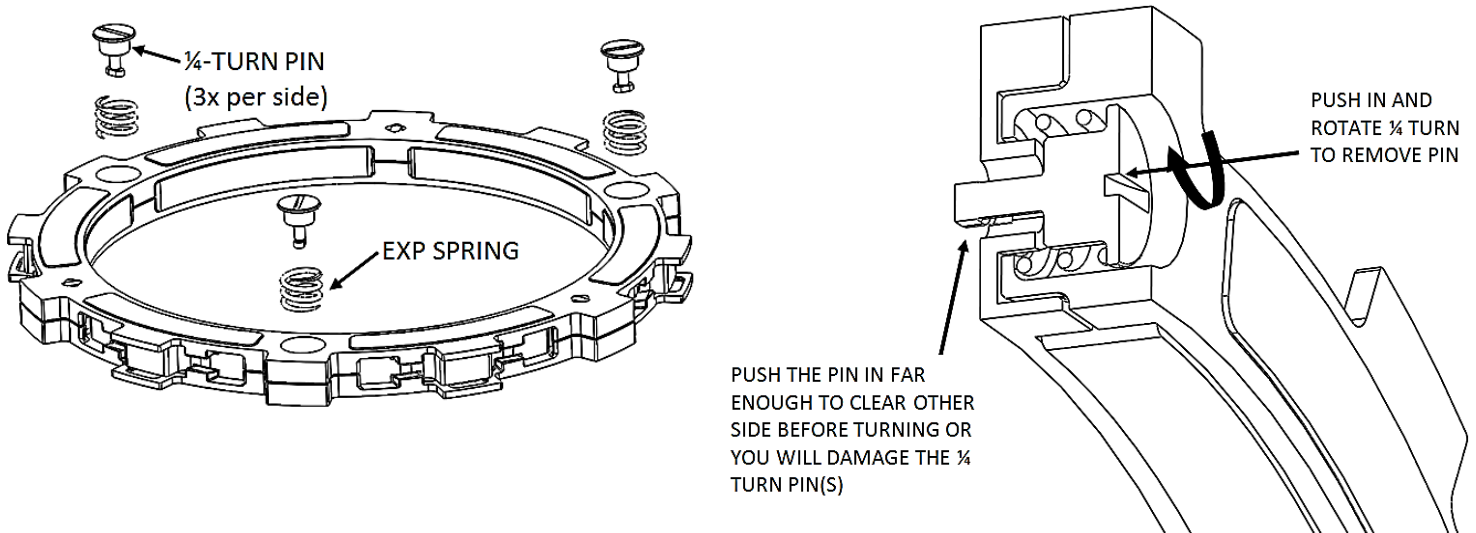

CAUTION: If you disassemble the EXP, bearing pads may fall out or be stuck to the ramp surfaces of the EXP bases. Take care to ensure all pads are correctly placed into wedge pockets using gentle pressure to avoid damage to the pad surfaces before reassembling the EXP. Properly seated pads will be secured in place once the EXP is reassembled. Operating the clutch without the pads in place will cause part damage or failure.

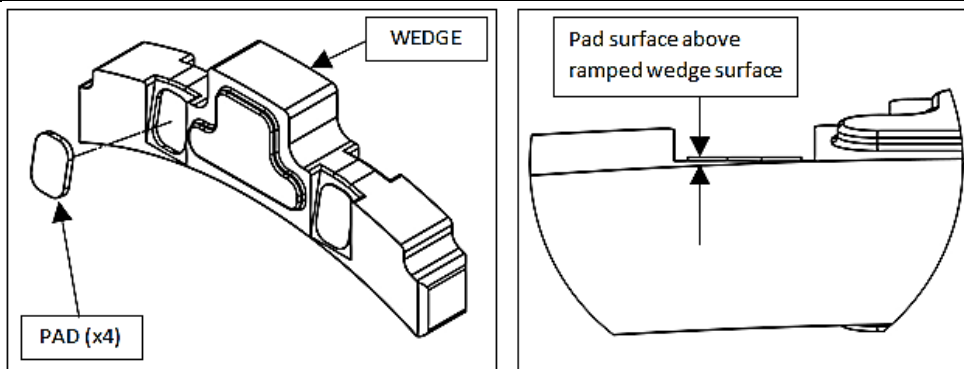

NEED ADDITIONAL HELP?

Website

www.rekluse.com/support

Frequently asked questions

www.rekluse.com/faq

Support Videos

www.rekluse.com/support/videos

Phone

(208) 426-0659

Technical Support

Contact Technical Support for questions related to product installation, tuning, and performance.

Hours:

Monday thru Friday: 8:00 a.m. - 5:00 p.m.

Mountain Time zone

Email: tech@rekluse.com

Customer Service

Contact Customer Service for additional product information, orders, and returns.

Hours:

Monday thru Friday: 8:00 a.m. - 5:00 p.m.

Mountain Time zone

Email: customerservice@rekluse.com

REKLUSE®



©2015 Rekluse Motor Sports
Rekluse Motor Sports, Inc.
support@rekluse.com