



REKLUSE[®]
CoreManual[™]

INSTALLATION & USER'S GUIDE

CoreManual Kit
For Cable-Actuated Motorcycles

Doc ID: 191-7008A
Revision: 121417

Table of Contents

OVERVIEW	2
INSTALLATION TIPS	2
TOOLS.....	3
INCLUDED PARTS	4
DISASSEMBLE CLUTCH.....	5
INSTALL THE HUB	7
INSTALL THE CLUTCH PACK	10
Notes for Clutch Pack Installation:	10
FINISH INSTALLTION.....	15
BREAK IN	16
MAINTENANCE.....	16
NEED ADDITIONAL HELP?.....	17

OVERVIEW

This kit replaces OE (Original Equipment) or “stock” core clutch components including the center clutch hub and pressure plate with high-quality billet components designed for optimal performance specific to your bike.

- All OE steel drive plates will be replaced with Rekluse drive plates.
- Most or all of the OE friction disks will be reused.
- Some kits may even include an extra stock friction disk, if the Rekluse CoreManual clutch will employ more friction disks than the stock clutch.

INSTALLATION TIPS

- Read the separate included Safety Information document before operating the vehicle with the product installed.



- Read this entire document before performing any steps.

- If you install this product for a customer or another person, instruct them to read the **Safety Information** document and the **Installation and User Guide** before operating the vehicle with the product.
- Protect eyes and skin – wear safety glasses and work gloves.
- Lay the bike on its left side when replacing the clutch. This makes working on the clutch easier and eliminates the need to drain the oil.
- Use an air or electric impact wrench to remove the center clutch nut. If one is not available, you can place the bike in top gear and hold the rear brake while loosening the center clutch nut with a socket and breaker bar.
- Channel-lock pliers work best to bend the tabs of the washer up over the center clutch nut.
- Use clean, quality JASO-MA or JASO-MA2 certified transmission oil for best performance.
- Use the torque values listed in the instructions. Otherwise, use the torque specifications found in your OE service manual.
- Inspect your OE cable for fraying and replace if needed.

TOOLS

- Metric socket set (at least 8 mm & 10 mm)
- 27 mm, 29 mm or 30 mm socket (for stock center clutch nut removal)
- 1¼” or 32 mm socket (for Rekluse center clutch nut installation, if included)
- Torque wrench (in-lb & ft-lb, or N-m)
- Channel-lock pliers

INCLUDED PARTS

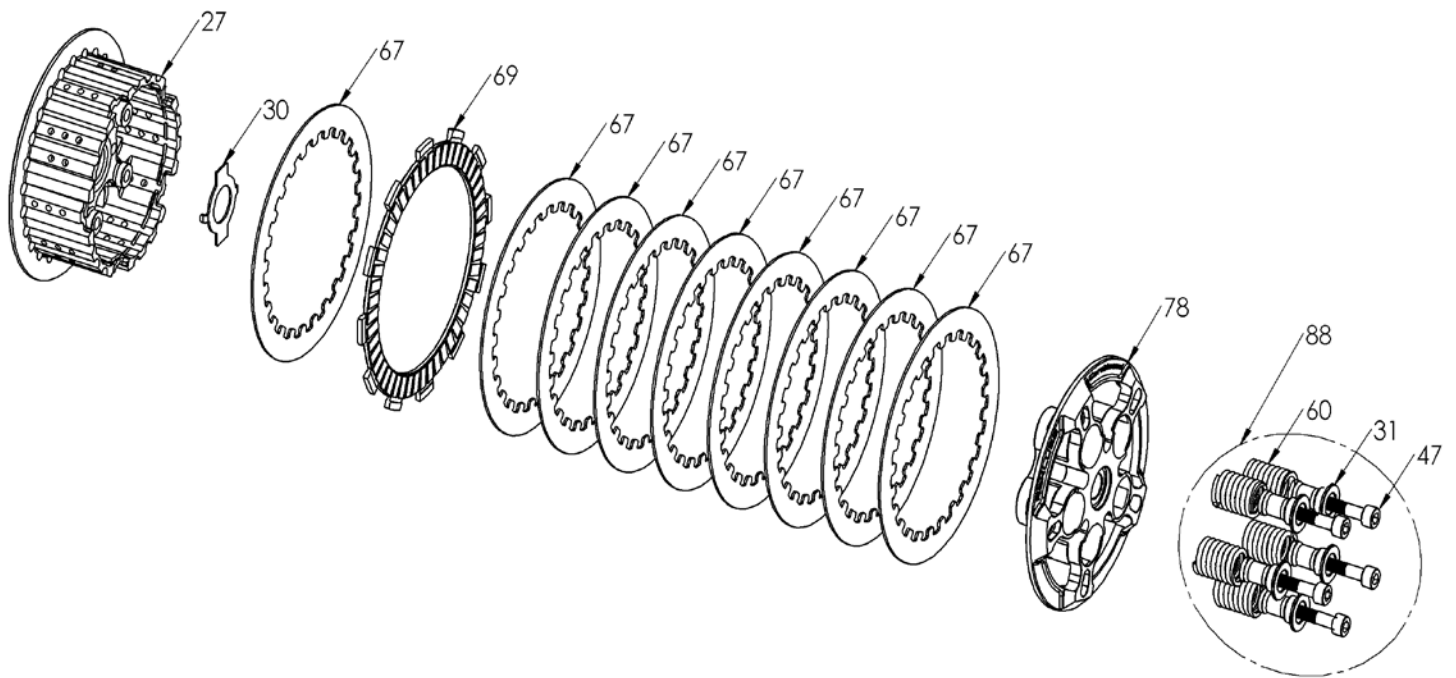

Item	Description	Qty.
27	Center clutch hub	1
30	Lock-tab washer	1
67	Thin steel drive plate - .040" (1.0mm), 250F models	9
Not shown	Thin steel drive plate - .040" (1.0 mm), 450F models	1
Not shown	Thick steel drive plates - .060" (1.5 mm), 450F models	8
78	Pressure plate	1
88	Core clutch spring assembly	1
60	Pressure plate springs	5 or 6
31	Screw sleeves	5 or 6
47	Socket head cap screws	5 or 6
69	OE style friction disk	1
Not shown	Clutch Cover (some models only)	1
Not shown	O-ring cord for use a clutch cover seal (some models only)	1

Visit www.rekluse.com/support for a full parts fiche illustration and part numbers.

DISASSEMBLE CLUTCH

1. Lay the bike on its left side. Catch any fuel that might drain in a suitable container.

2. If your clutch cover has an oil fill plug and/or engine inspection plug, loosen them before removing the clutch cover.



3. Using a socket, remove the OE clutch cover.

4. Remove the following OE parts from the clutch basket.

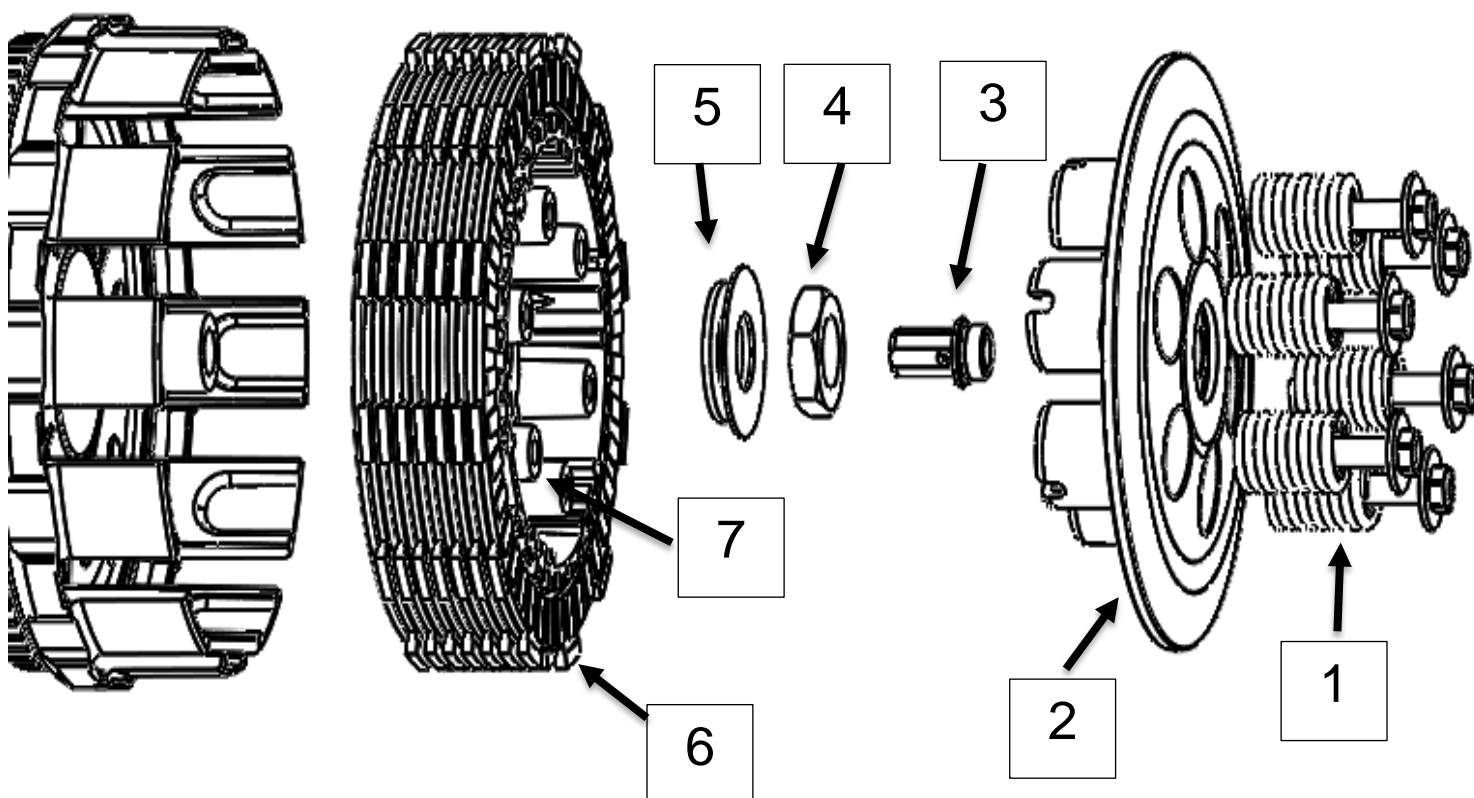

1	Pressure plate springs and bolts – 5 or 6 depending on bike model
2	Pressure plate
3	Throw-out
4	Center clutch nut
5	Lock washer(s) – 1 or 2 depending on bike model
6	OE Clutch pack
7	OE inner hub

5. Along with the clutch pack, remove the judder (boss) spring, seat, and narrow friction from the clutch basket.

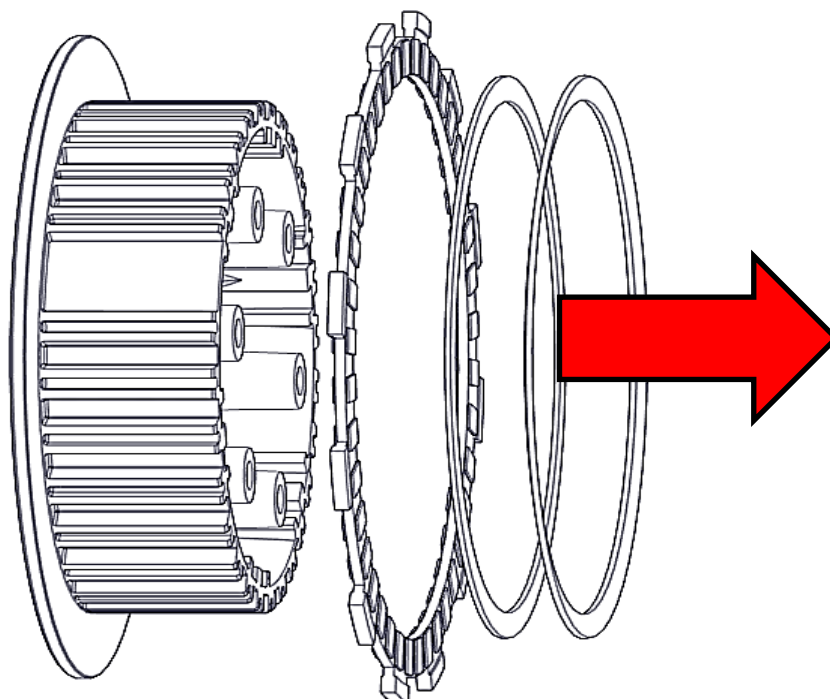

6. Separate the OE clutch pack. All the friction disks will be reused. All the drive plates will be replaced with Rekluse steel drive plates.

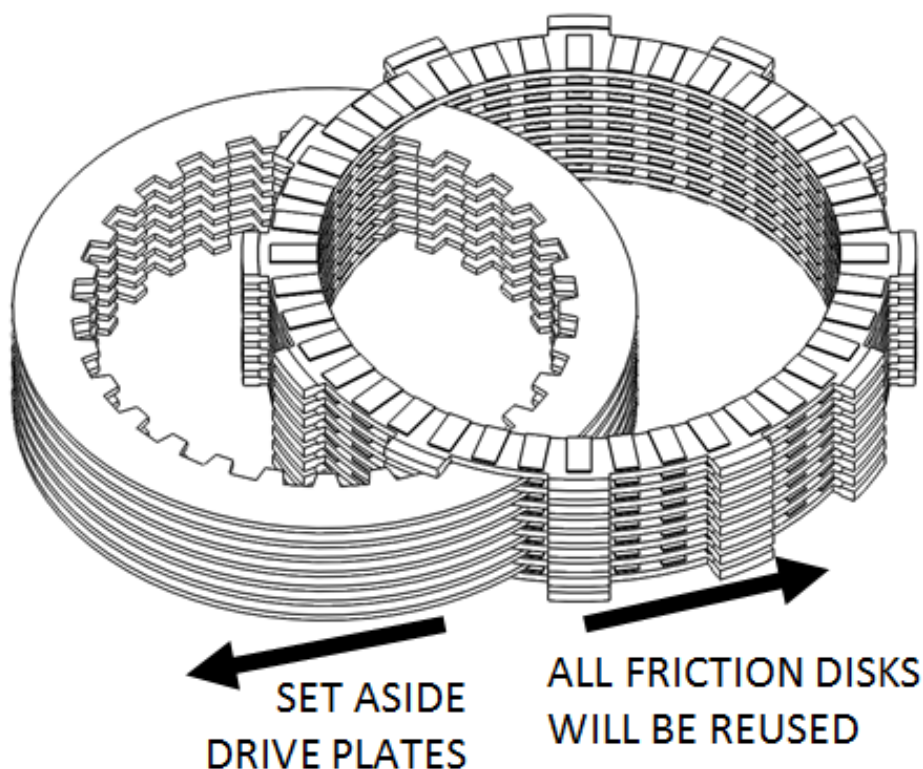

7. Inspect the friction disks for signs of heat or wear. Replace if they are burnt or worn.

Note: For most models, new friction disks can be purchased from Rekluse, or through your local OE dealer.



8. Inspect the clutch basket for damper/cushion play or notching.

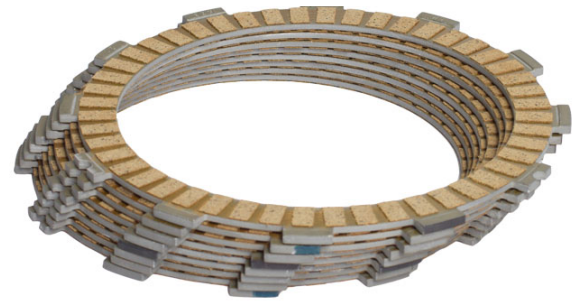

⚠ WARNING

Failure to inspect the basket and replace if necessary could result in death, serious injury, and/or property damage.

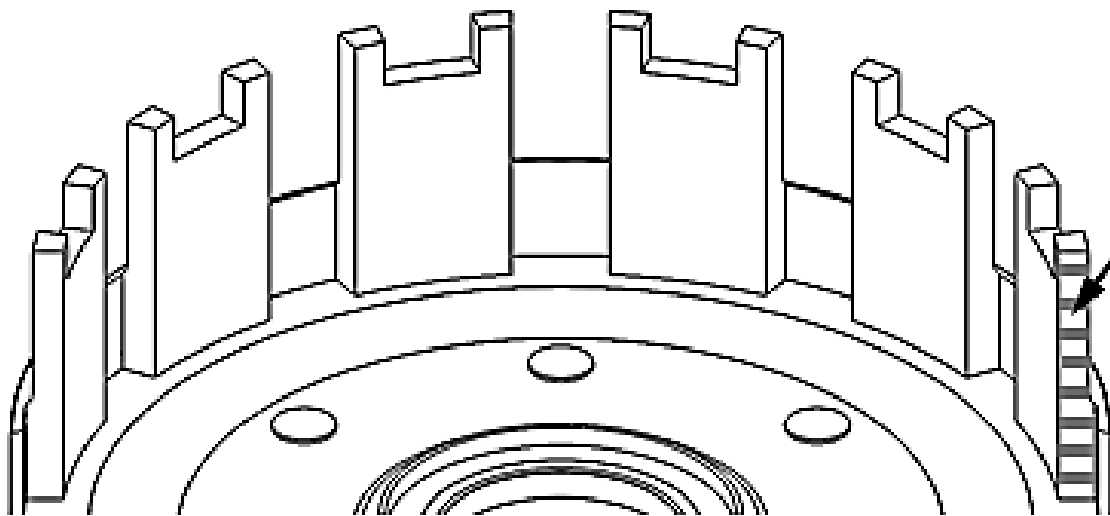

INSPECT FOR NOTCHING IN TANG FACES

(REPLACE IF NOTCHED)

Note: If the basket is notched or worn, Rekluse recommends replacing it with a Rekluse Billet Clutch Basket (available for most models).



INSTALL THE HUB

1. Check to make sure the OE thrust washer is still on the main shaft.

Note: If the OE thrust washer is missing, it might be stuck to the bottom of the OE center hub assembly. The thrust washer must be installed or clutch performance issues will result.

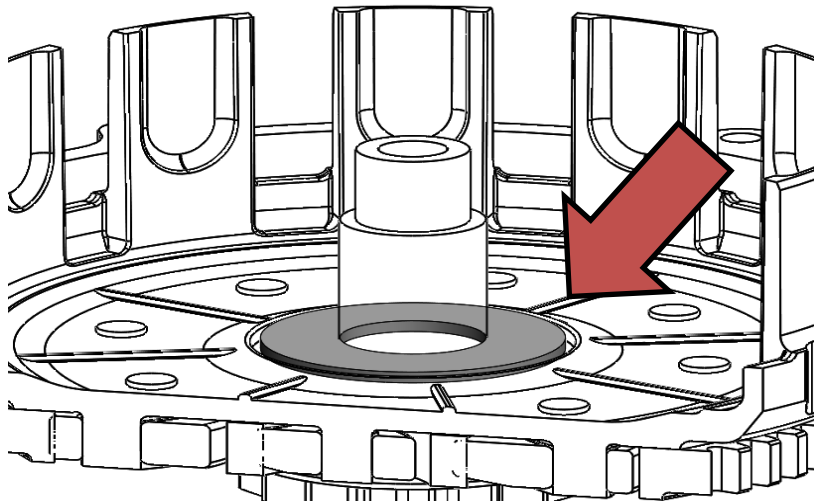

2. Install the new Rekluse center hub into the clutch basket.

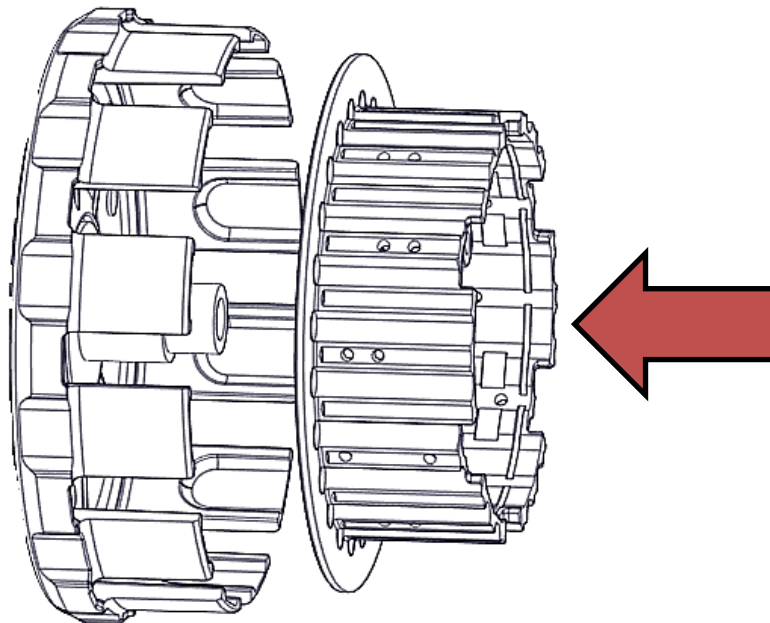

3. Install the new Rekluse tab washer with the bent tabs facing down, aligning with the holes in the hub. *Only use the supplied lock tab washer under the OE center clutch nut when installing the hub.*



4. Install the OE center clutch nut.

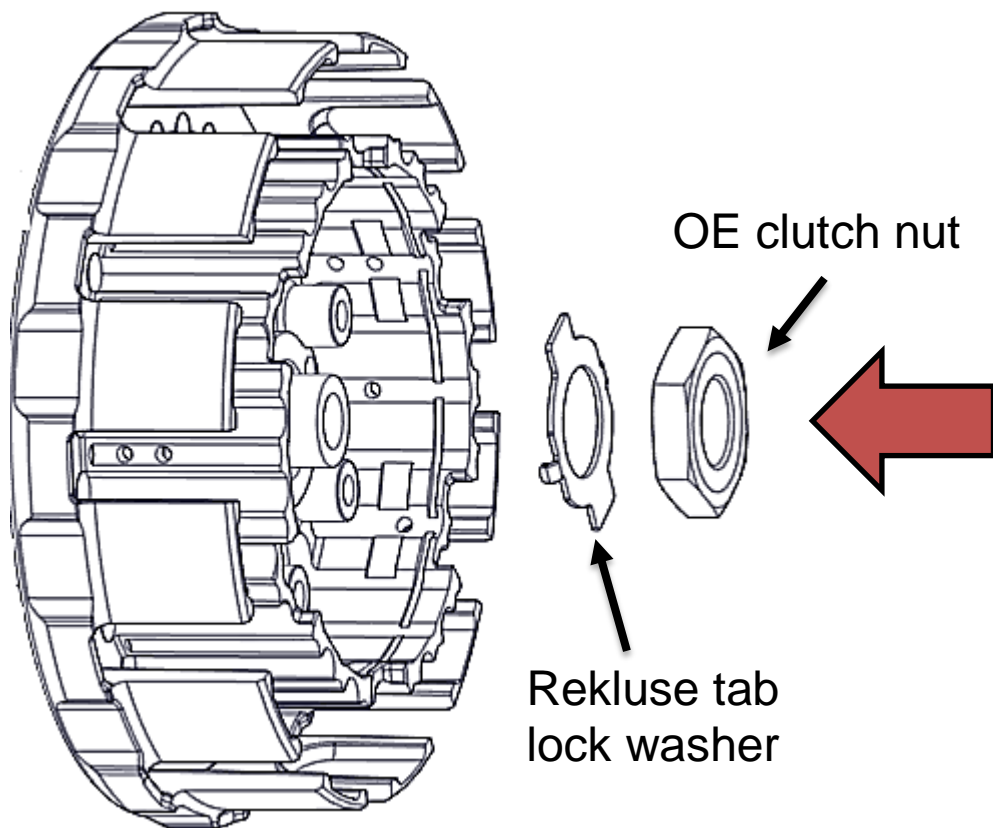

5. Using the socket and torque wrench, torque the center clutch nut to **50 ft-lb (68 N-m)**.

Note: *Placing the bike in the highest gear and holding the rear wheel by applying the rear brake keeps the shaft from rotating when tightening the nut.*

6. Using the channel-lock pliers, bend up **both** tabs of the tab washer tightly around the nut. The tabs can be bent on the straight sides or around the corners.

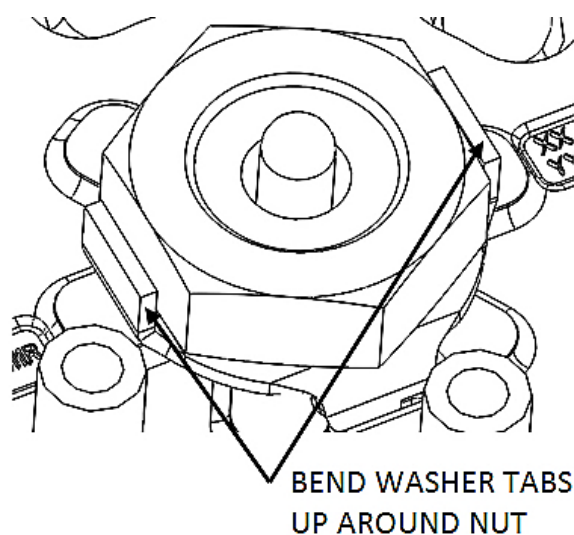

INSTALL THE CLUTCH PACK

Notes for Clutch Pack Installation:

- Some friction disks are marked with a small colored dot. This mark is used for processing and can be ignored.
- Some OE basket have “half slots” at the top of the basket tangs. Rekluse products require the entire clutch pack be installed into the MAIN (deeper) basket slots. Installing the pack in the “half slots” will cause performance issues. See the following picture for reference.

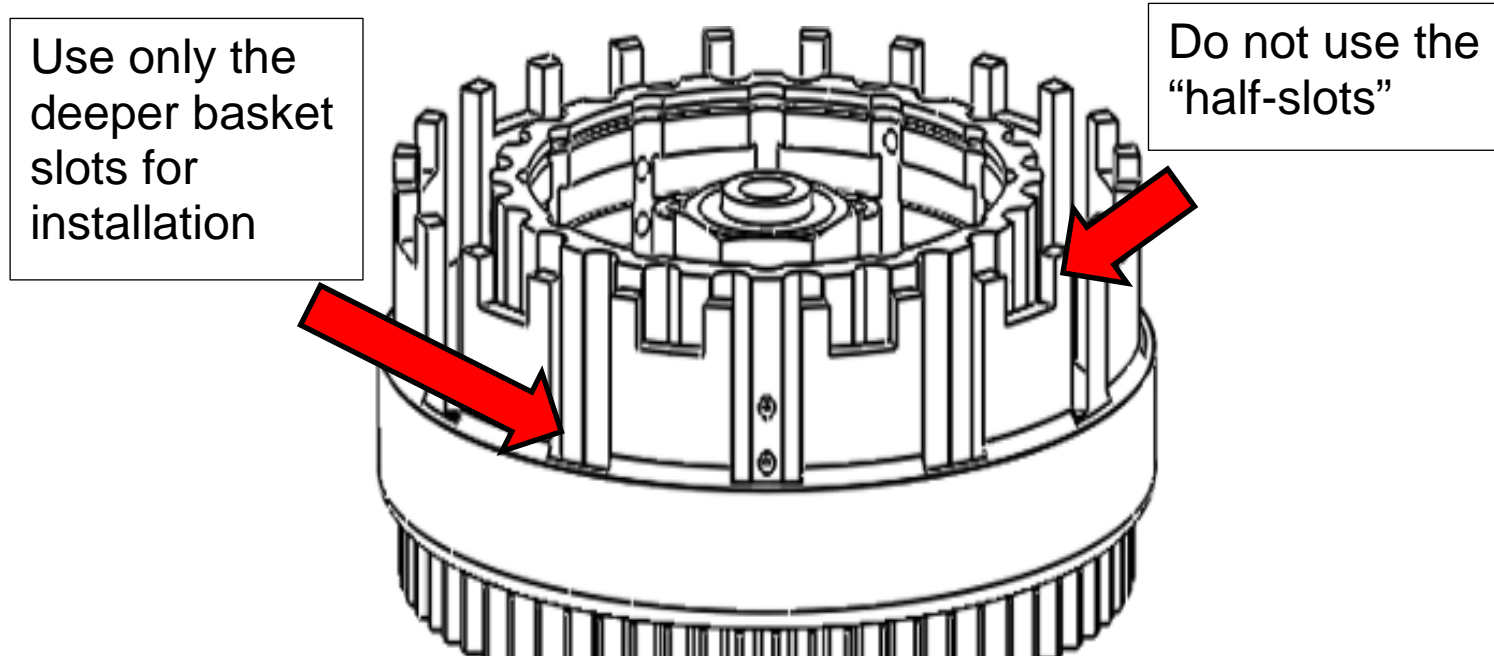

1. If a friction disk was included with your kit, place the included friction disk in engine oil to soak for at least 5 minutes.

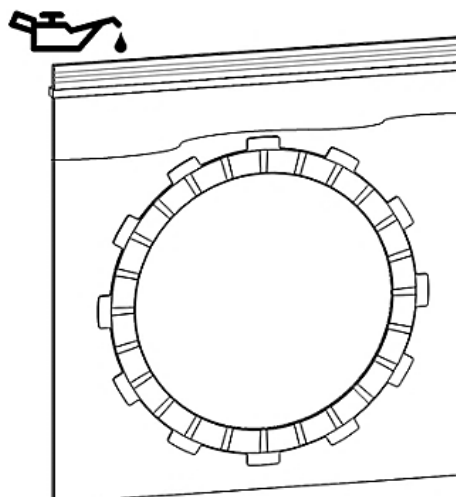

NOTE: Only some models will require an extra friction disk. Not all kits are supplied with one.

2. The clutch pack order depends on the type of bike. Select the instructions for your bike to begin installing the clutch pack, then continue with step 3.

For 450F bikes:

- a. Install the clutch pack starting with the **thin** - .040" (1.0 mm) steel drive plate.
- b. Install the OE narrow friction disk.
- c. Install the judder (boss) seat, then install the judder spring, cupped side up.

Note: *Installing the judder spring is optional and the clutch pack can be installed without it. Installing the judder spring will reduce clutch noise, and may increase modulation slightly.*

- d. Add a steel drive plate, then alternate OE friction disks with the **thick** - .060" (1.5 mm) steel drive plates. *The last plate in will be a steel drive plate.*

450F Clutch Pack

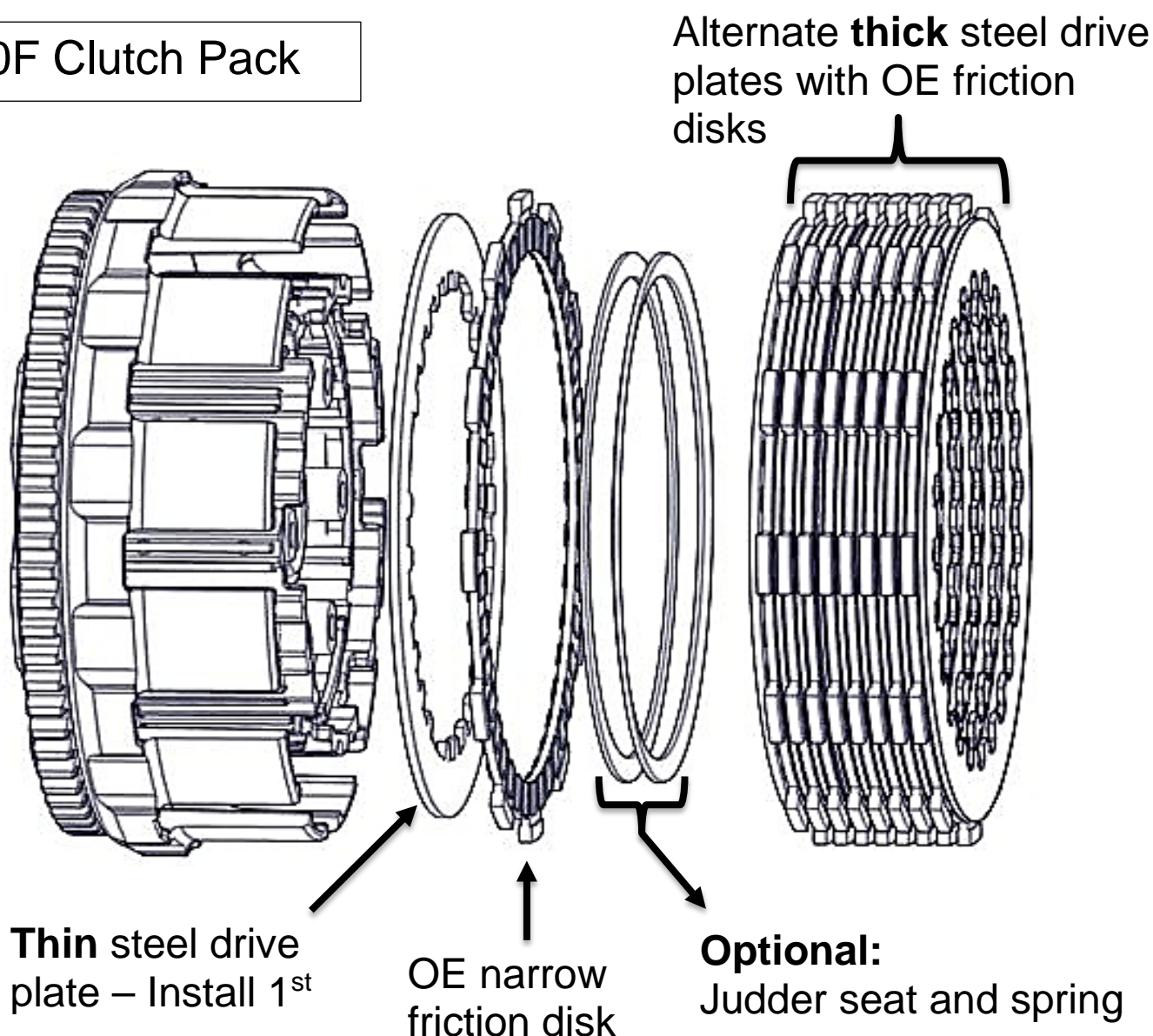

450F Cross-section

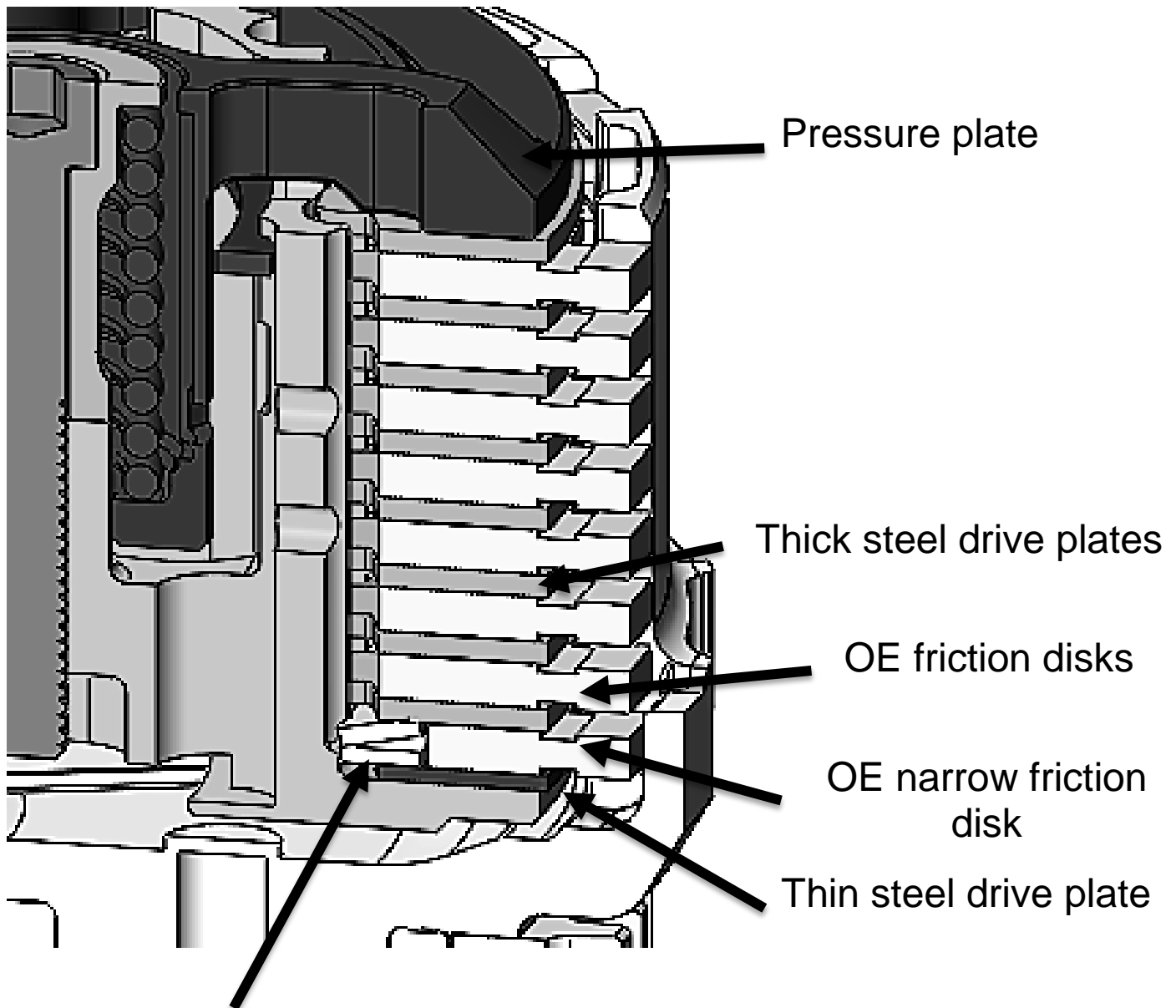

Optional: judder seat and spring- cupped side up

For 250F bikes:

- a. Install the clutch pack starting with a steel drive plate, then install the Rekluse provided OE style friction disk.

Note: *The clutch pack is installed **without** the judder spring and seat.*

- b. Continue to alternate OE friction disks with Rekluse steel drive plates for the entire clutch pack. *The last plate in will be a steel drive plate.*

250F Clutch Pack

Alternate steel drive plates with OE friction disks

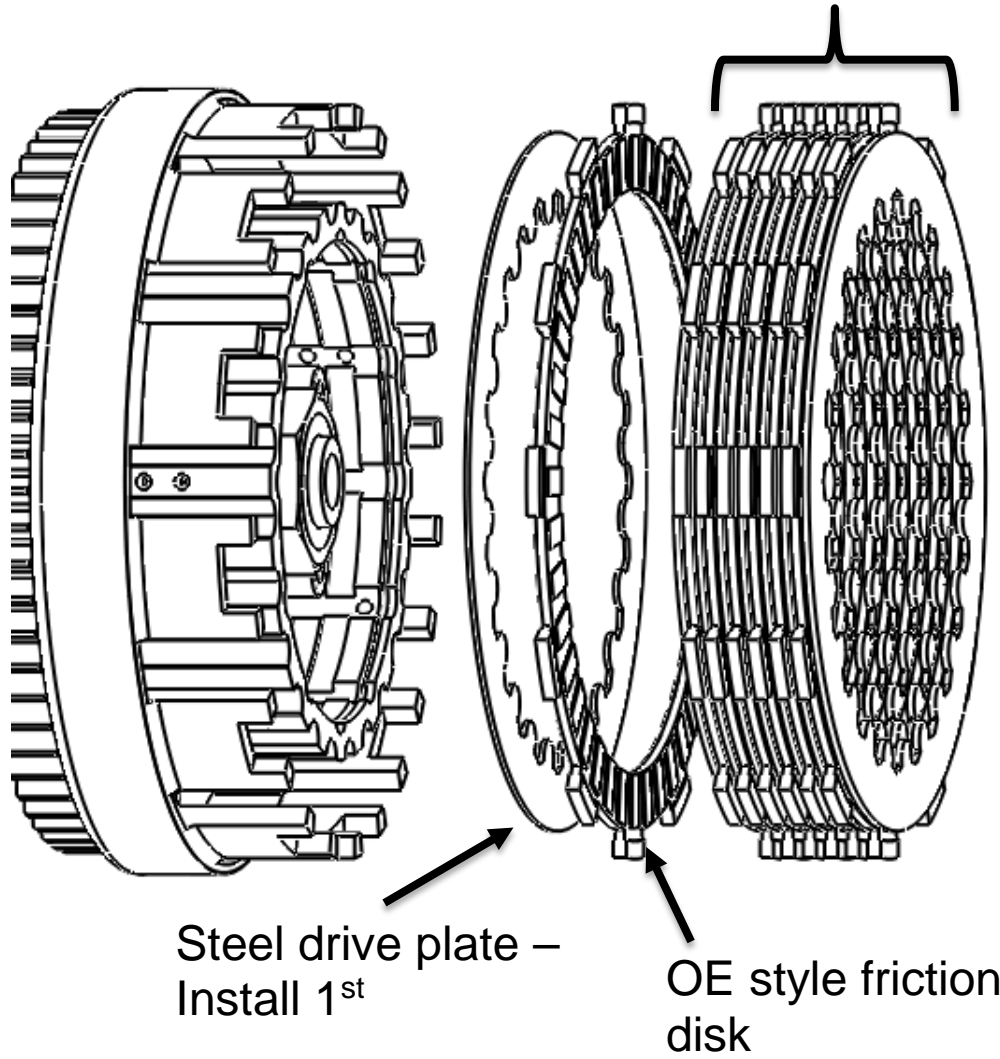

250F Cross-section

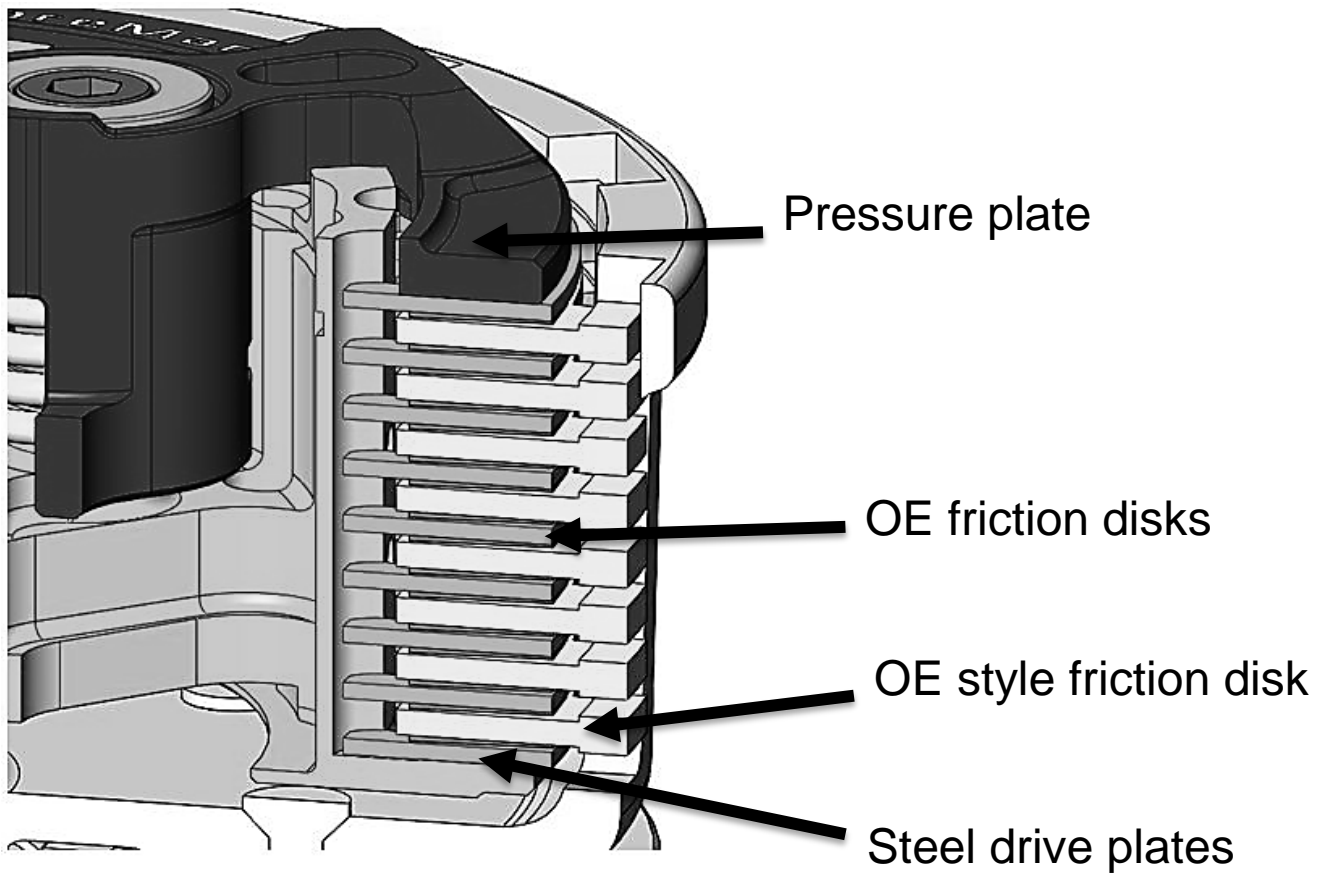

3. Reinstall the OE throw-out, then install the Rekluse pressure plate.

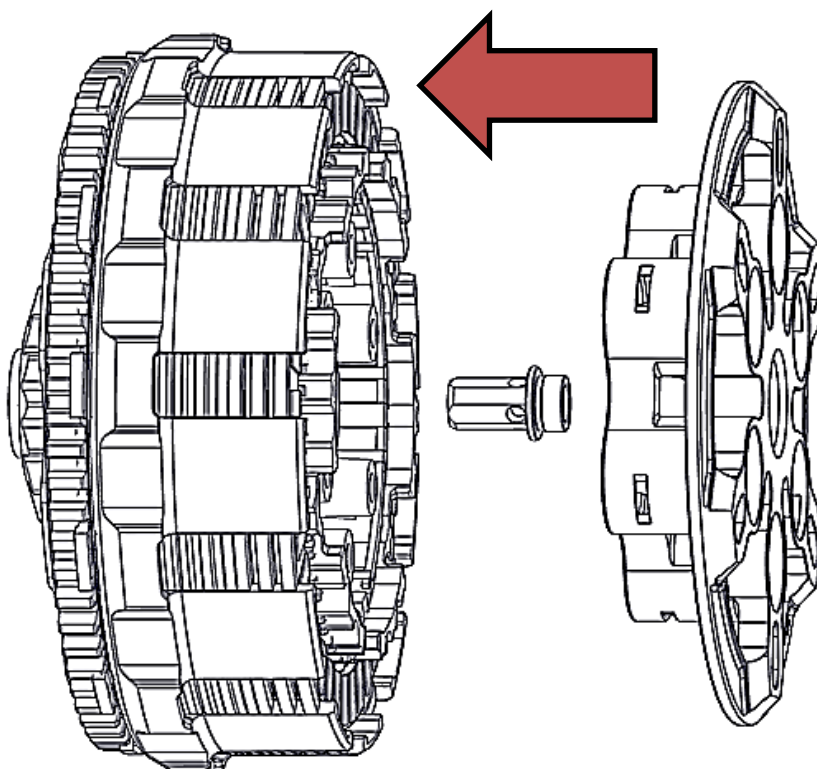

4. Install the pressure plate springs, followed by the screw sleeves and socket head cap screws (5 or 6 depending on the bike). Alternative spring options are available from Rekluse if desired. The springs provided are the recommended setting for optimum balance of performance and lever feel.

Note: *If two different spring colors are provided with your kit, be sure to alternate the springs by color in every other pocket.*

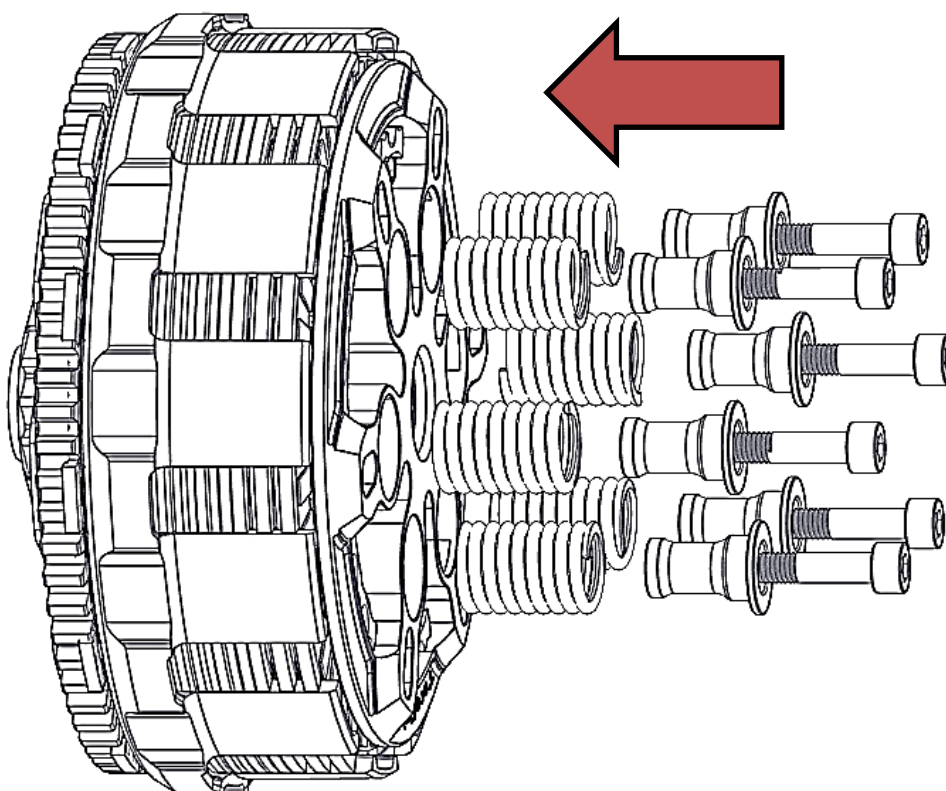

5. Use a torque wrench and socket to torque the cap screws by lightly tightening the screws in small increments. Torque the cap screws to 9 ft-lb (12 N-m).

FINISH INSTALLTION

1. Most CoreManual kits fit under the stock clutch cover. However, if your kit comes with a Rekluse clutch cover, you will install it in place of the OE cover to avoid internal interference and engine damage.
 - A. If your kit did not come with a Rekluse clutch cover, reinstall the OE clutch cover.
 - B. If your kit came with a Rekluse clutch cover, install the OE cover gasket onto the Rekluse cover, then install the cover.

For all Honda models:

A cut-to-fit O-ring cord is supplied with your kit. Install the O-ring cord onto the clutch cover. Make sure the ends of the cord meet at the top of the clutch cover to prevent leaks. It can be helpful to use super-glue to connect the ends of the cord, once cut to length to fit your cover.

2. Reinstall the clutch cover bolts, then lightly tighten the cover bolts in small increments in a star pattern. Torque the cover bolts to OE specifications.

3. If your clutch cover has an oil fill plug and/or engine inspection plug, reinstall the plug.

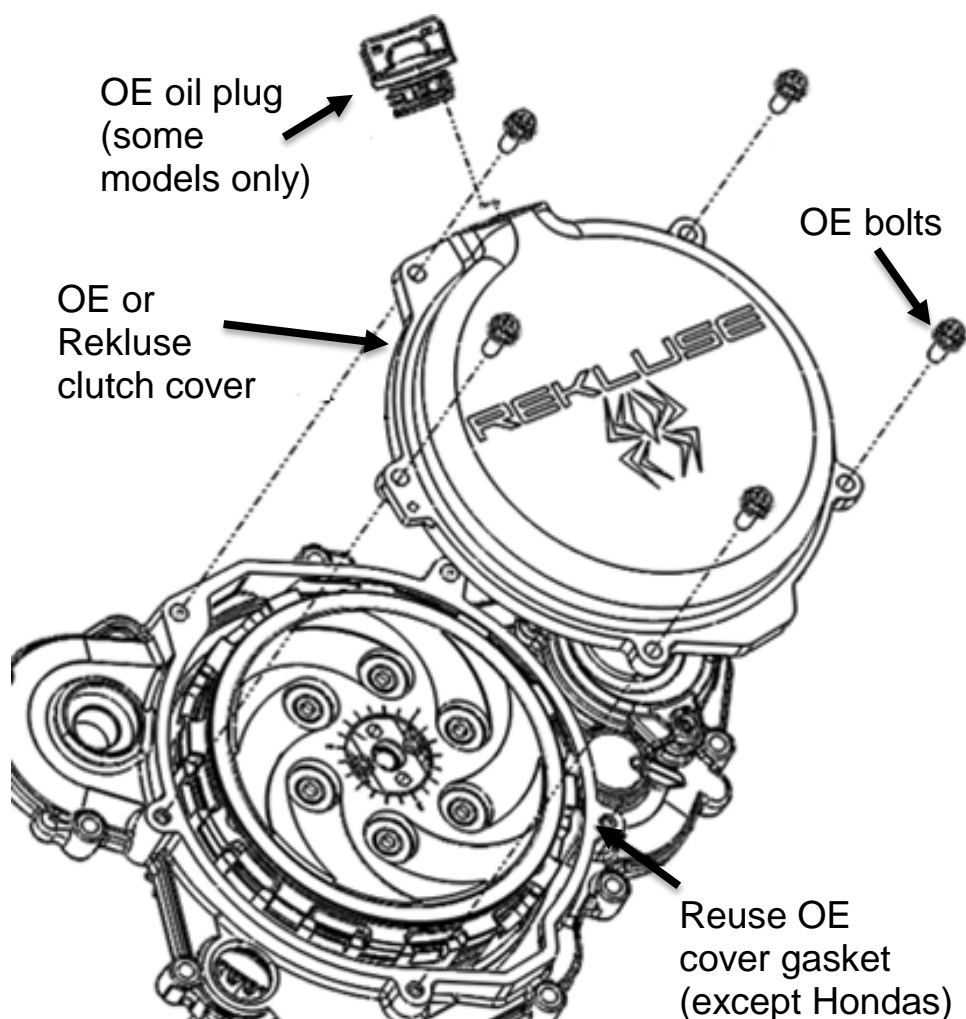

4. Readjust lever free play to OE specification (10-20 mm).

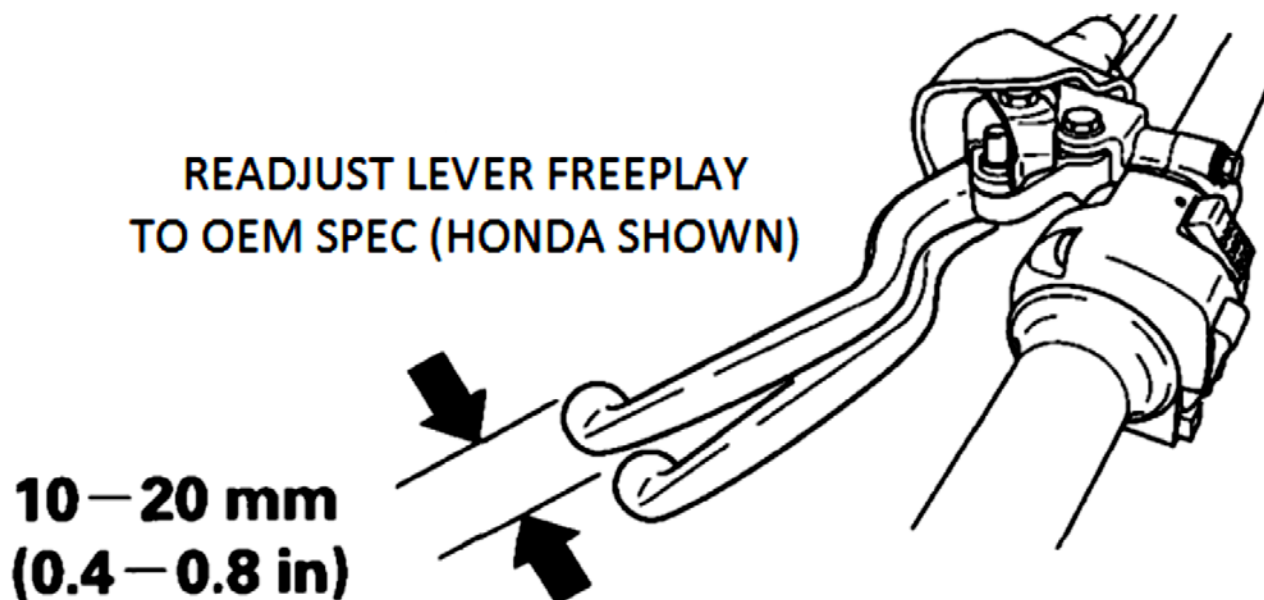

BREAK IN

Break-in will occur over the first 1-2 hours of use, depending on the rider. During break-in more clutch drag may occur than normal.

MAINTENANCE

- Inspect all of your clutch parts at regular maintenance intervals for signs of wear or excessive heat, and replace components as necessary. Clutch wear is very dependent on the riders use, inspection interval may vary.
- Keep up with regular oil changes and other bike maintenance. Ultimately, better clutch longevity and performance is greatly increased with oil quality and other bike factors that reduce engine heat.
- Replace friction disks regularly for best clutch component life, especially if they appear glazed and/or burnt upon inspection.

NEED ADDITIONAL HELP?

Website

www.rekluse.com/support

Frequently Asked Questions

www.rekluse.com/faq

Support Videos

www.rekluse.com/support/videos

Phone

(208) 426-0659

Technical Support

Contact Technical Support for questions related to product installation, tuning, and performance.

Hours:

Monday thru Friday: 8:00 a.m. - 5:00 p.m.

Mountain Time zone

Email: tech@rekluse.com

Customer Service

Contact Customer Service for additional product information, orders, and returns.

Hours:

Monday thru Friday: 8:00 a.m. - 5:00 p.m.

Mountain Time zone

Email: customerservice@rekluse.com

