



REKLUSE MOTOR SPORTS

The Rekluse Core Manual Clutch

INSTALLATION GUIDE

191-7002
Manual Revision: 112112

©2012 Rekluse Motor Sports
Rekluse Motor Sports, Inc.
12000 W Franklin Rd
Boise, Idaho 83709
208-426-0659
support@rekluse.com

OVERVIEW

To complete the installation, you will be performing the following steps:

- Removal of your stock pressure plate, clutch pack and center clutch
- Installation of the Rekluse Core center clutch
- Installation of Rekluse drive plates with **8** friction plates from the stock clutch
- Installation of the Rekluse Manual pressure plate, springs and bolts

INSTALLATION TIPS

- Be sure to use proper eye protection
- Laying the bike on it's side makes it easier to work on the clutch and eliminates the need to drain the oil
- An air or electric impact wrench works well to remove the center clutch nut
 - or place the bike in top gear and hold the rear brake while loosening the center clutch nut
- Channel-lock style pliers work best to bend the tabs of the lock washer up over the center clutch nut

TOOLS NEEDED

- 27mm socket (for stock center clutch nut)
- 5mm hex key (for Rekluse bolts)
- Channel locks (to bend tabs of Rekluse tab lock washer)
- 8mm, 10mm socket (for removing clutch cover and stock springs)

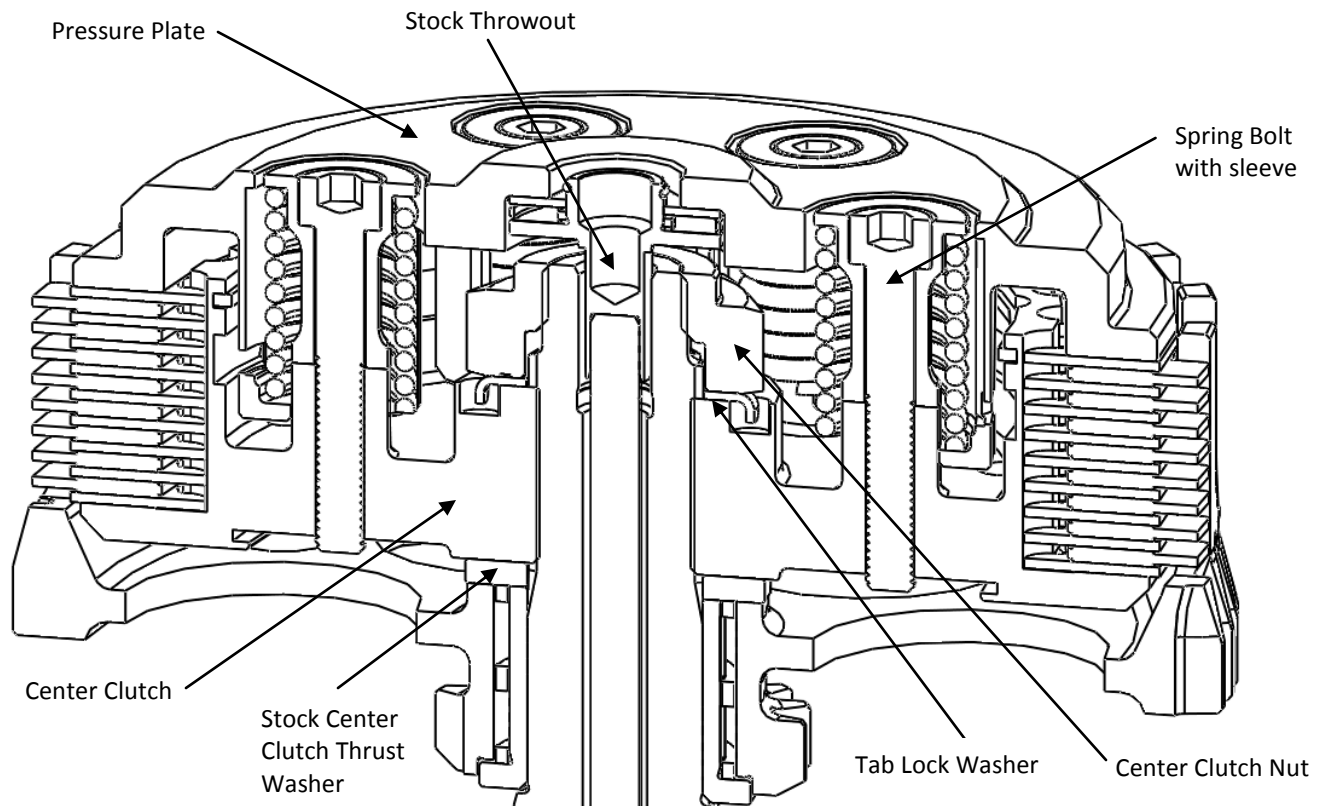

1. Turn the fuel to off and place the bike in 4th or 5th gear.
2. Lay the motorcycle on its left side and remove the clutch cover.
3. If you already have a Rekluse Core Clutch with EXP installed, remove the EXP Pressure Plate and EXP Friction Disk and skip to step 8.
4. Remove OEM Pressure Plate, springs, center clutch, throw-out, and clutch pack.

NOTE: OEM throw-out with needle bearing and flat washer and the friction plates will be re-installed. OEM thrust washer behind OEM center clutch will be re-installed.

5. Install the Rekluse center clutch, with OEM thrust washer behind it, onto the main shaft.

NOTE: You must re-use the OEM Thrust Washer that goes between the outer basket and Center Clutch Hub.

6. Install the Rekluse tab lock washer so the 2 pre-bent tabs index down into the 2 corresponding holes of the Rekluse center clutch.
7. Re-install the OEM center clutch nut and torque to the recommended value specified on your motorcycle owner's manual. Once torqued, bend the tabs of the Rekluse tab lock washer up to secure the nut.

8. Configure clutch pack as shown below and install onto Rekluse center clutch. You will install **8 OEM frictions** and 9 drive plates starting with a Rekluse Steel Plate.

NOTE: If you are converting from EXP to Manual Mode, remove the EXP plate and replace with 1 OEM friction disk and 1 Rekluse Steel Plate.

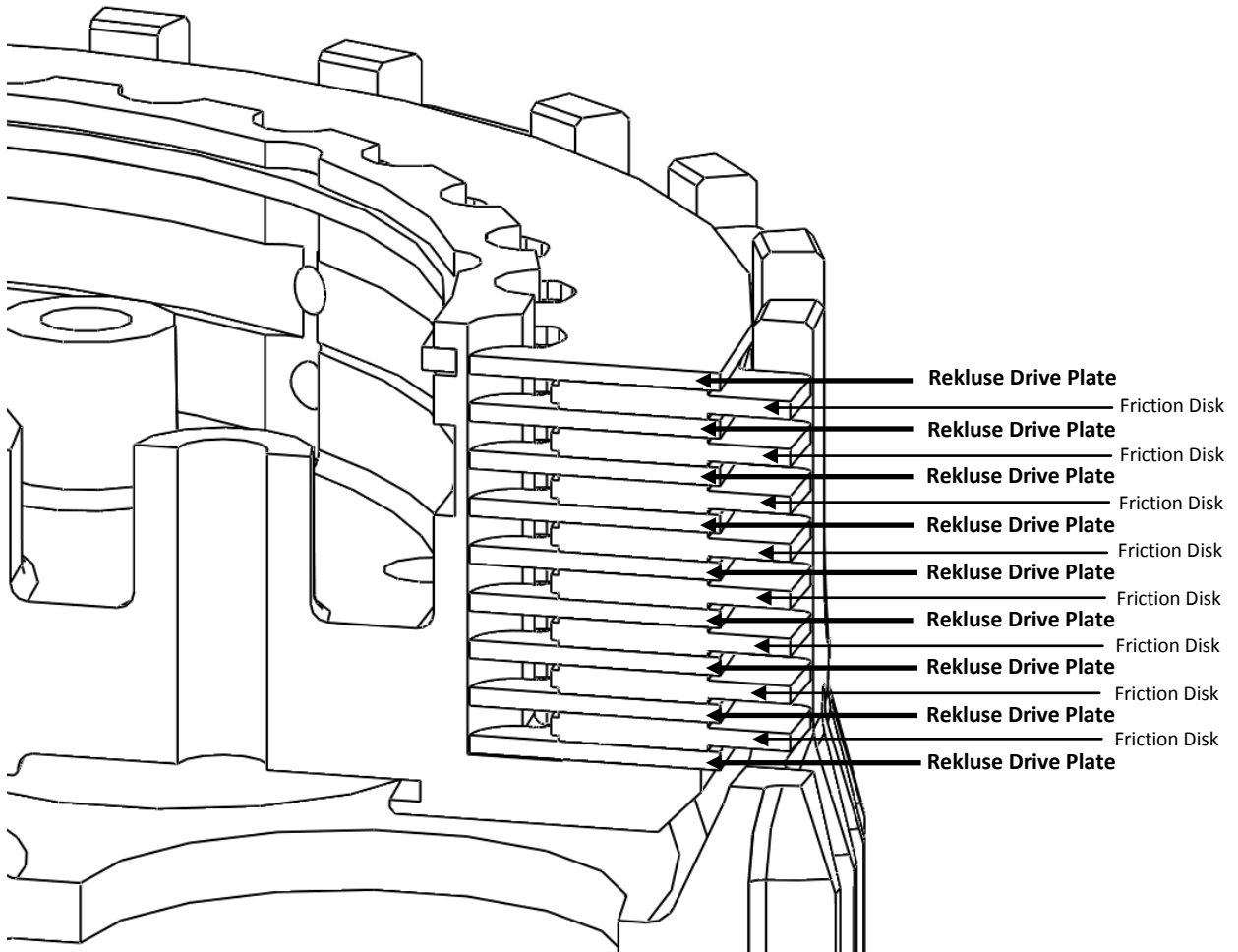

9. Install the OEM throw-out, with needle bearing and flat washer on top of it, onto the throw-out rod.

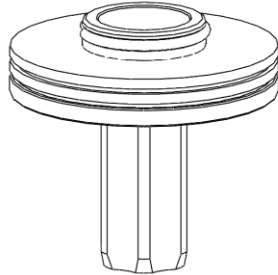

12. Re-install the clutch cover with the OEM gasket.

10. Install the Pressure Plate so the holes in the bottom of the spring cups slide over the center clutch standoffs.

11. Install the included Rekluse springs into the pockets of the pressure plate. Place the spacers and bolts into the springs and thread each bolt in a couple of turns. **Rotate each spring one turn counter-clockwise to ensure the spring is properly located in its spring pocket** (see picture below).

Torque each bolt to 9 ft-lbs (12 N-m).

