



REKLUSE[®] CoreManual[™]

REKLUSE MOTOR SPORTS

The Rekluse Core Manual Clutch

INSTALLATION GUIDE

191-7001
Manual Revision: 021815

©2015 Rekluse Motor Sports
Rekluse Motor Sports, Inc.
12000 W Franklin Rd
Boise, Idaho 83709
208-426-0659
support@rekluse.com

OVERVIEW

To complete the installation, you will be performing the following steps:

- Removal of your stock pressure plate, clutch pack and center clutch
- Installation of the Rekluse Core center clutch
- Installation of Rekluse drive plates with **8** friction plates from the stock clutch pack (exception: KTM 125/144/150/200, KTM/Husqvarna 85/105)
- Installation of the Rekluse Manual pressure plate, springs and bolts

INSTALLATION TIPS

- Be sure to use proper eye protection
- Laying the bike on it's side makes it easier to work on the clutch and eliminates the need to drain the oil
 - Be sure to turn off the gas, work in a ventilated area and be prepared to catch any gas that may drain from vent tubes
- An air or electric impact wrench works well to remove the center clutch nut
 - or place the bike in top gear and hold the rear brake while loosening the center clutch nut
- Channel-lock style pliers work best to bend the tabs of the lock washer up over the center clutch nut

TOOLS NEEDED

- 27mm socket (for stock center clutch nut)
- 5mm hex key (for Rekluse bolts)
- Channel locks (to bend tabs of Rekluse tab lock washer)
- 8mm, 10mm socket (for removing clutch cover and stock springs)

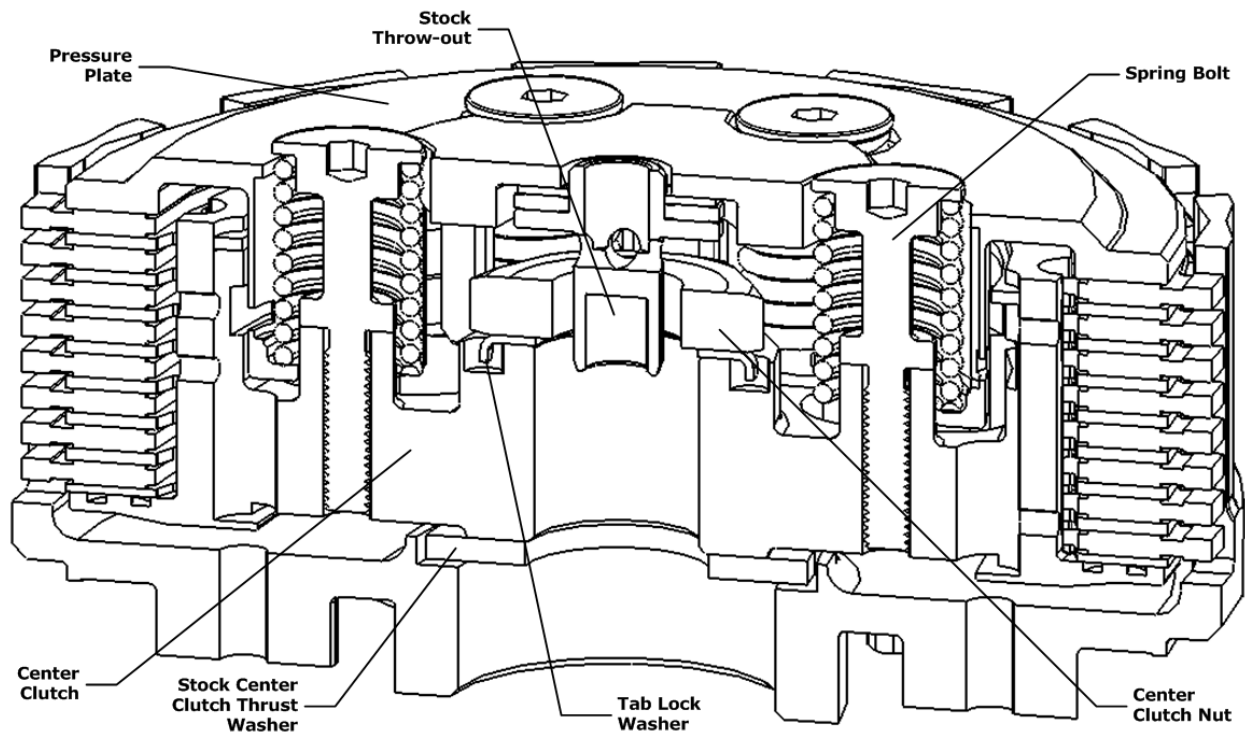

1. Turn the fuel to off and place the bike in 4th or 5th gear.
2. Lay the motorcycle on its left side and remove the clutch cover.
3. If you already have a Rekluse Core Clutch with EXP installed, remove the EXP Pressure Plate and EXP Friction Disk and skip to step 8.
4. Remove OEM Pressure Plate, springs, center clutch, throw-out, and clutch pack.

NOTE: The OEM throw-out assembly, frictions and thrust washer behind OEM center clutch will be re-installed, unless you are a: **Beta, Husqvarna 450/510 or Gas Gas owner:** These will need the supplied Rekluse throw-out, needle bearing and thrust washers in place of the OEM throw-out assembly. If you are converting from EXP to Manual Mode re-use the Rekluse throw-out assembly.

5. Install the Rekluse center clutch, with OEM thrust washer behind it, onto the main shaft.

NOTE: You must re-use the OEM Thrust Washer that goes between the outer basket and Center Clutch Hub.

6. Install the Rekluse tab lock washer so the 2 pre-bent tabs index down into the 2 corresponding holes of the Rekluse center clutch.

KTM/Husqvarna 85/105 Owners Only: Reuse your OEM lock tab washer.

7. Re-install the OEM center clutch nut and torque to the recommended value specified on your motorcycle owner's manual. Once torqued, bend the tabs of the Rekluse tab lock washer up to secure the nut. For 125cc+ bikes, 50 ft-lbs (68 Nm) can be used. For 85/105cc models, 40 ft-lbs (54 Nm) can be used. **This is critical to ensure minimal clutch drag!**

- Configure clutch pack as shown below and install onto Rekluse center clutch. You will install **8 OEM frictions** and 8 drive plates starting with a Rekluse Steel Plate. See the following exceptions:

NOTE: 450 class bikes and 250+ 2-strokes: The first plate installed is the 0.040" Rekluse Steel Plate.

NOTE: Some models use 9 friction disks stock – with Rekluse Core you only use 8.

KTM 125/144/150/200 Owners Only: Your clutch will use only 7 friction disks and 7 total steel plates.

Beta Owners only:

If you are converting from EXP to Manual Mode, remove the EXP plate and replace with 2 OEM friction disks and 2 Rekluse Steel plates. With the Core Manual clutch the clutch pack is configured as per Step 8 and the picture below.

KTM/Husqvarna 85/105, and Husqvarna 250F/310F Owners Only:

The stock configuration has 7 friction disks – with Core Manual use the extra friction disk that is included to make 8 total frictions.

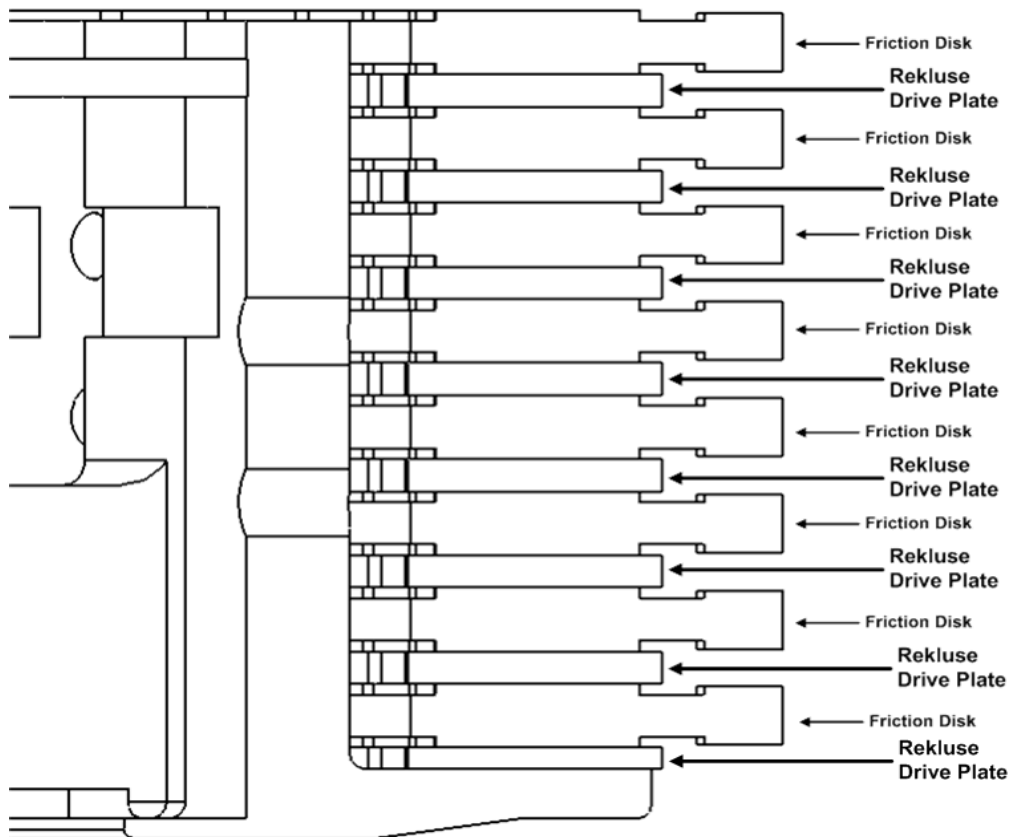

9. **Beta, Husqvarna 450/510 and Gas Gas owners only:**

Install the included Rekluse throw-out assembly in the order shown in the following diagram on top of the stock throw-out rod.

NOTE: If you are converting from EXP to Manual Mode re-use the Rekluse throw-out assembly.

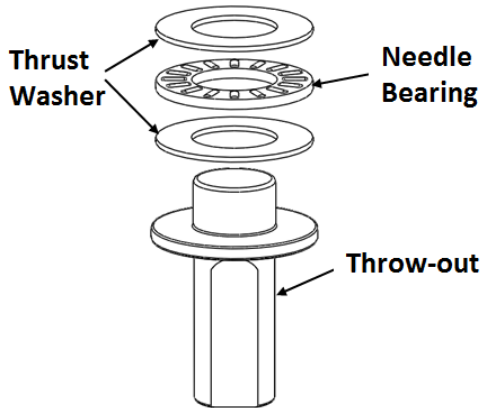

All other bike models: Install the OEM throw-out with needle bearing and thrust washer on top of the OEM throw-out rod (pic shown below).

NOTE: If you are missing the flat washer, it is probably stuck to the backside of your OEM pressure plate.

Also: The picture shown below is a likeness to most OEM throw-out assemblies, so yours may differ from what's shown.

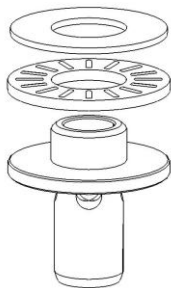

10. Install the Pressure Plate so the holes in the bottom of the spring cups slide over the center clutch standoffs.

11. Install the included Rekluse springs into the pockets of the pressure plate. Place the spacers and bolts into the springs and thread each bolt in a couple of turns. **Rotate each spring one turn counter-clockwise to ensure the spring is properly located in its spring pocket** (see picture below).

Torque each bolt to 9 ft-lbs (12 N-m).

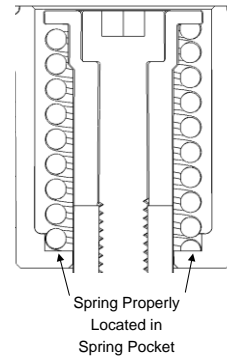

12. Re-install the clutch cover with the OEM gasket.